



LECTURE NOTES

ON

BASIC ELECTRICAL ENGINEERING

B. Tech II semester



UNIT-I

Introduction to Electrical Engineering

Ohms Law: At constant temperature potential difference across the conductor is directly proportional to current flowing through the conductor is called ohms law.

$$V \propto I$$

$$V=IR$$

where the constant of proportionality R is called the resistance or electrical resistance, measured in ohms (Ω). Graphically, the $V - I$ relationship for a resistor according to Ohm's law is depicted in Figure

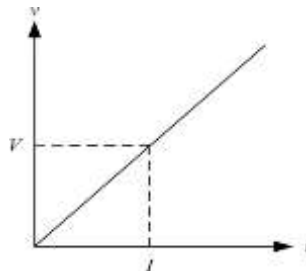
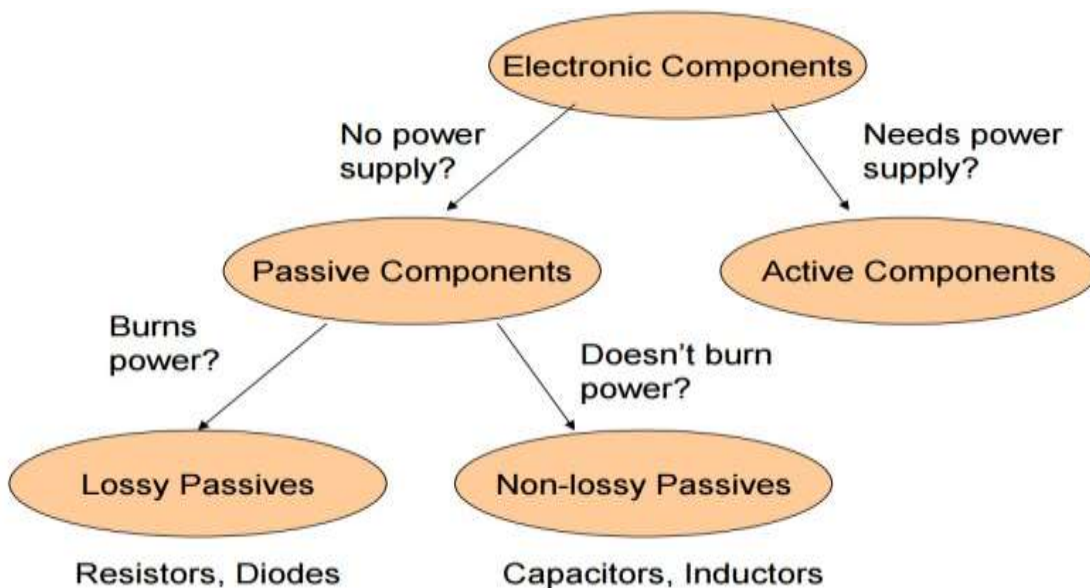

Figure $V - I$ relationship for a resistor according to Ohm's law.

At any given point in the above graph, the ratio of voltage to current is always constant

basic circuit components:



Circuit Element	Voltage	Current
Resistor	$V = IR$	$I = \frac{V}{R}$
Inductor	$v = L \frac{di}{dt}$	$i = \frac{1}{L} \int v dt$
Capacitor	$v = \int_0^t i dt + v(0) C$	$i = C \frac{dv}{dt}, i = 0 \text{ for DC}$

$V - I$ relationships for a resistor, inductor and capacitor.

Kirchhoff's Voltage Law (KVL)

Kirchhoff's Voltage Law states that the algebraic sum of voltages around each loop at any instant of time is zero

$$\Sigma \text{ voltage drops} = \Sigma \text{ voltage rises}$$

Kirchhoff's Current Law (KCL)

Kirchhoff's Current Law states that The algebraic sum of currents a node at any instant is zero.

$$\Sigma \text{ currents in} = \Sigma \text{ currents out}$$

Basic Definitions:

Current: the directed flow of electrons (charge) called current. It is denoted by I. units are Amps

Electrical potential: charged body capacity to do work is known as its electrical potential.

Potential difference: difference in potentials of two charged bodies is called Potential difference

Power: the rate at which an electrical work done in electrical work is called power. It is denoted by P. units are Watt

Electrical work: Electrical work is said to be done when there is transfer of charge. It is denoted by W. units are joules.

Energy: capacity to do work is called energy.

Electrical Network: A combination of various electric elements (Resistor, Inductor, Capacitor, Voltage source, Current source) connected in any manner what so ever is called an electrical network

Classification of element:

We may classify circuit elements in two categories, passive and active elements.

Passive Element: The element which receives energy (or absorbs energy) and then either converts it into heat (R) or stored it in an electric (C) or magnetic (L) field is called passive element.

Active Element: The elements that supply energy to the circuit is called active element. Examples of active elements include voltage and current sources, generators

Bilateral Element: Conduction of current in both directions in an element (example: Resistance; Inductance; Capacitance) with same magnitude is termed as bilateral element

Unilateral Element: Conduction of current in one direction is termed as unilateral (example: Diode, Transistor) element

Linear Circuit: Roughly speaking, a linear circuit is one whose parameters do not change with voltage or current. More specifically, a linear system is one that satisfies (i) homogeneity property (ii) additive property

Non-Linear Circuit: Roughly speaking, a non-linear system is that whose parameters change with voltage or current. More specifically, non-linear circuit does not obey the homogeneity and additive properties.

DC Sources

In general, there are two main types of DC sources

1. Independent (Voltage and Current) Sources
2. Dependent (Voltage and Current) Sources

An independent source produces its own voltage and current through some chemical reaction and does not depend on any other voltage or current variable in the circuit. The output of a dependent source, on the other hand, is subject to a certain parameter (voltage or current) change in a circuit element. Herein, the discussion shall be confined to independent sources only.

DC Voltage Source

This can be further subcategorised into ideal and non-ideal sources.

The Ideal Voltage Source An ideal voltage source, shown in Figure has a terminal voltage which is independent of the variations in load. In other words, for an ideal voltage source, the supply current alters with changes in load but the terminal voltage, V_L always remains constant. This characteristic is depicted in Figure .

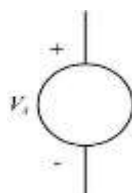

(a) An ideal voltage source.



(b) $V - I$ characteristics of an ideal voltage source.

Figure: Schematic and characteristics of an ideal voltage source

Practical Voltage Source For a practical source, the terminal voltage falls off with an increase in load current. This can be shown graphically in Figure. This behavior can be modeled by assigning an internal resistance, R_S , in series with the source as shown in Figure

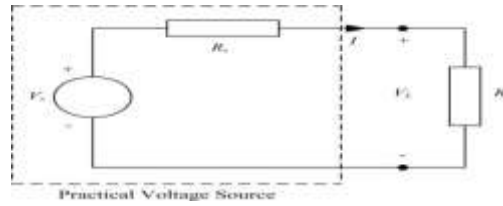
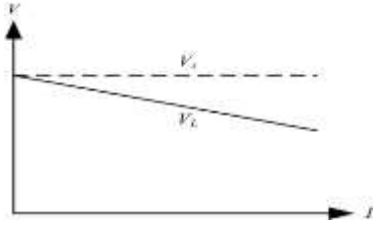

Where R_L represents the load resistance. The characteristic equation of the practical voltage source can be written as

$$V_L = V_S - R_S I$$

For an ideal source, $R_S = 0$ and therefore $V_L = V_S$.

Resistive Circuits

Series Resistors

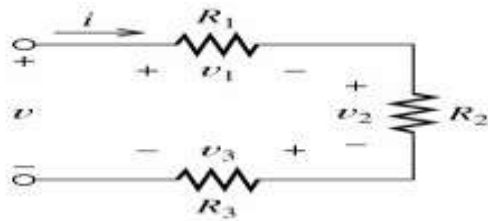

(a) Three resistances in series

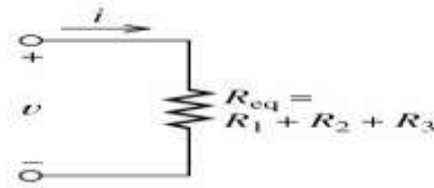

(b) Equivalent resistance

Parallel Resistors

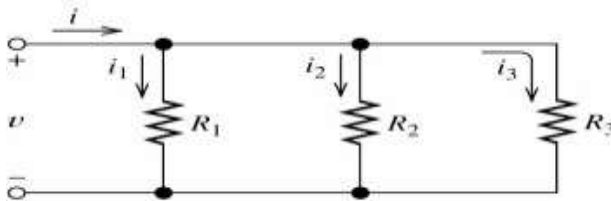

(a) Three resistances in parallel

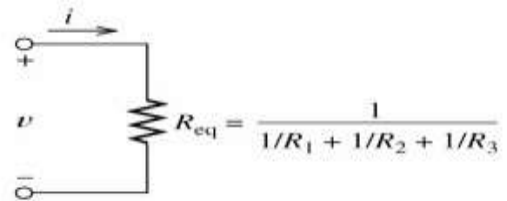

(b) Equivalent resistance

Series Inductors

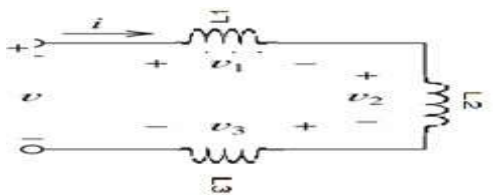

(a) Three inductances in series

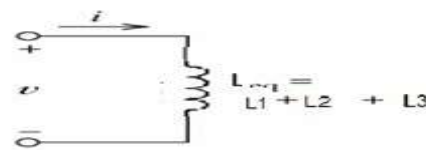

(b) Equivalent Inductances

Parallel Inductors

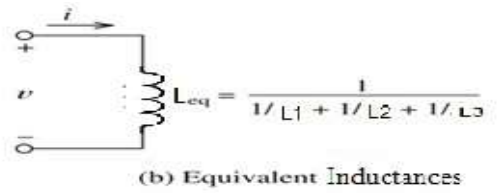
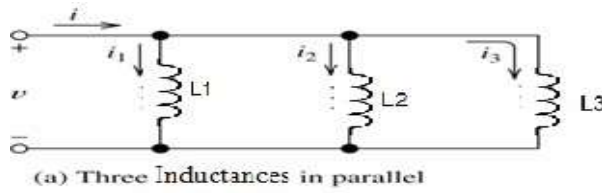

Series Capacitors

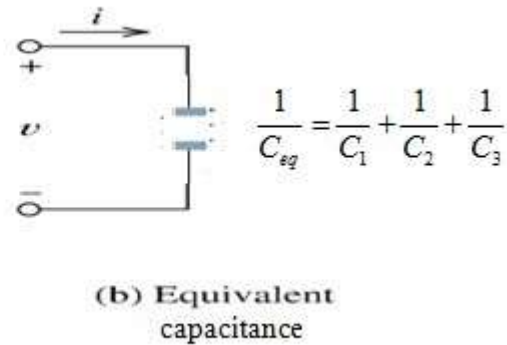
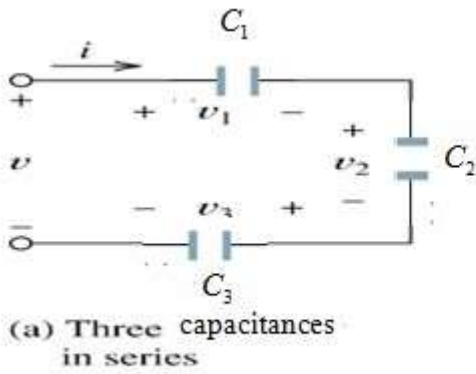

Parallel Capacitors

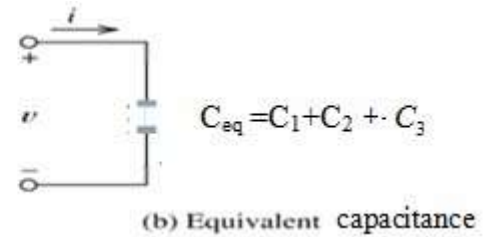
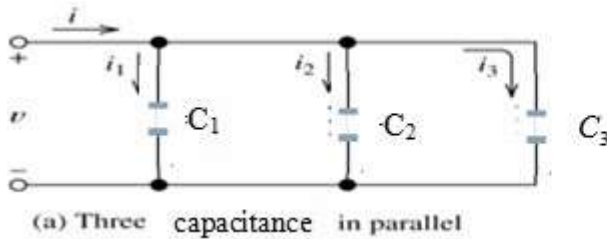

Delta – Star Conversion

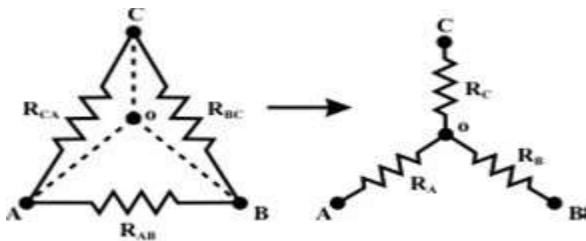

$$R_A = \frac{R_{AB} R_{CA}}{R_{AB} + R_{BC} + R_{CA}}$$

$$R_B = \frac{R_{AB} R_{BC}}{R_{AB} + R_{BC} + R_{CA}}$$

$$R_C = \frac{R_{BC} R_{CA}}{R_{AB} + R_{BC} + R_{CA}}$$

Star -Delta Conversion

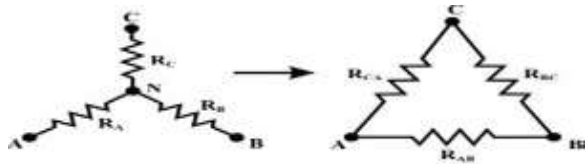

$$R_{AB} = R_A + R_B + \frac{R_A R_B}{R_C}$$

$$R_{AC} = R_A + R_C + \frac{R_A R_C}{R_B}$$

$$R_{BC} = R_B + R_C + \frac{R_B R_C}{R_A}$$

Superposition Theorem

Superposition theorem is extremely useful for analysing electric circuits that contains two or more active sources. In such cases, the theorem considers each source separately to evaluate the current through or voltage across a component. The resultant is given by the algebraic sum of all currents or voltages caused by each source acting independently. Superposition theorem can be formally stated as follows

“The current through or voltage across any element in a linear circuit containing several sources is the algebraic sum of the currents or voltages due to each source acting alone, all other sources being removed at that time.”

Linearity is a necessary condition for the theorem to apply. Fortunately, the v, i relationship for R , and C are all linear. The sources can be removed using the following methodology

1. Ideal voltage sources are short-circuited
2. Ideal current sources are open-circuited

In general, practical sources are replaced by their internal resistances.

Thévenin's Theorem

Thévenin's theorem provides a useful tool when solving complex and large electric circuits by reducing them to a single voltage source in series with a resistor. It is particularly advantageous where a single resistor or load in a circuit is subject to change.

Formally, the Thévenin's theorem can be stated as

“Any two-terminal linear electric circuit consisting of resistors and sources, can be replaced by an equivalent circuit containing a single voltage source in series with a resistor connected across the load.”

In the circuit diagrams shown in Figure, the current I_L through the load resistance R_L is the same. Hence the circuits are equivalent as far as the load resistor R_L is concerned.

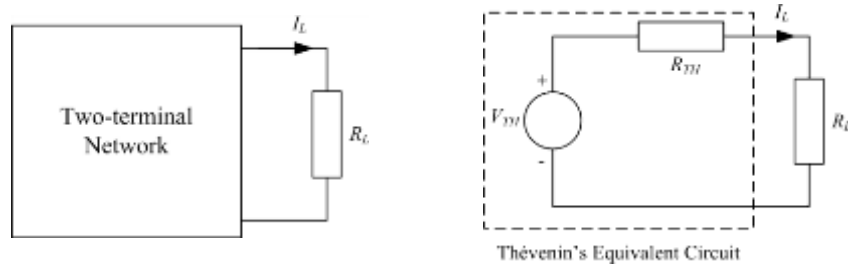

Figure : Illustration of Thévenin's theorem.

The following steps outline the procedure to simplify an electric circuit using Thévenin's theorem where V_{TH} and R_{TH} are the Thévenin's voltage and Thévenin's resistance respectively.

1. Remove the load resistance R_L .
2. V_{TH} is the open circuit (OC) voltage across the load terminals and
3. R_{TH} is the resistance across the load terminals with all sources replaced by their internal resistances.

Alternatively, measure the OC voltage across, and the short circuit (SC) current through the load terminals.

Then

$$V_{TH} = V_{oc} \text{ and } R_{TH} = V_{oc} / I_{sc}$$

Maximum Power Transfer Theorem

As discussed in the section on Thévenin's theorem, any DC network of sources and resistances can be replaced by a single voltage source in series with a resistance connected across the load (see Figure). The maximum power transfer theorem states that the power delivered to the load is maximum when the load resistance, R_L is equal to the internal (source) resistance, R_S of the DC power supply. In other words, it can be said that the load resistance must match the Thévenin's resistance for maximum power transfer to take place i.e.,

$$(R_S = R_{TH}) = R_L$$

When this occurs, the voltage across the load resistance will be $\frac{V_S}{2}$ and the power delivered to the load is given by

The above equation is plotted in Figure which clearly demonstrates maximum power delivered when $R_S = R_L$.

Under this condition, the maximum power will be

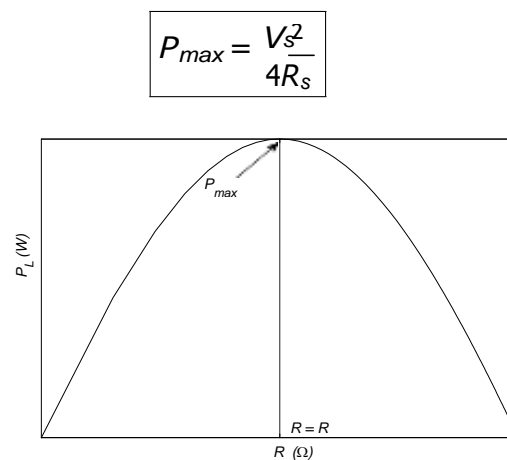

Figure: Illustration of maximum power transfer the



HI-TECH INSTITUTE OF TECHNOLOGY, KHURDA, BHUBANESWAR,

UNIT-II

Alternating Quantities

Principle of AC voltage: Consider a rectangular coil of N turns placed in a uniform magnetic field as shown in the figure. The coil is rotating in the anticlockwise direction at a uniform angular velocity of ω rad/sec

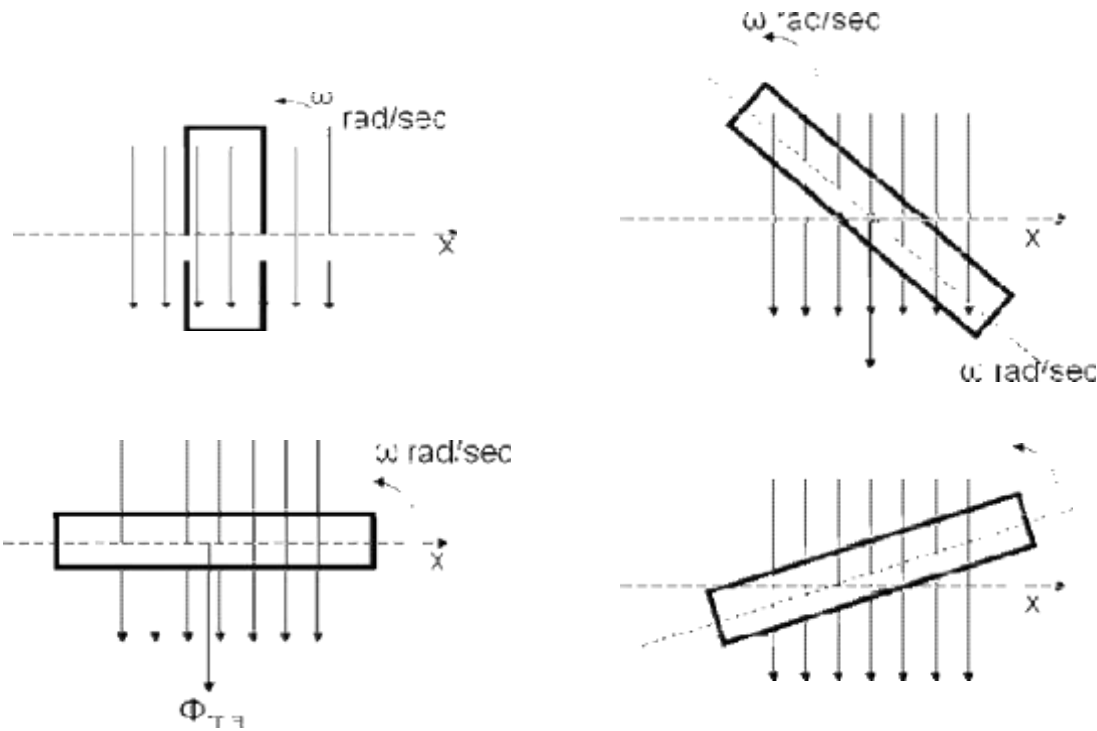

When the coil is in the vertical position, the flux linking the coil is zero because the plane of the coil is parallel to the direction of the magnetic field. Hence at this position, the emf induced in the coil is zero. When the coil moves by some angle in the anticlockwise direction, there is a rate of change of flux linking the coil and hence an emf is induced in the coil. When the coil reaches the horizontal position, the flux linking the coil is maximum, and hence the emf induced is also maximum. When the coil further moves in the anticlockwise direction, the emf induced in the coil reduces. Next when the coil comes to the vertical position, the emf induced becomes zero. After that the same cycle repeats and the emf is induced in the opposite direction. When the coil completes one complete revolution, one cycle of AC voltage is generated. The generation of sinusoidal AC

Voltage can also be explained using mathematical equations. Consider a rectangular coil of N turns placed in a uniform magnetic field in the position shown in the figure. The maximum flux linking the coil is in the downward direction as shown in the figure. This flux can be divided into two components, one component acting along the plane of the coil $\Phi_{\max}\sin\omega t$ and another component acting perpendicular to the plane of the coil $\Phi_{\max}\cos\omega t$.

ω rad/sec

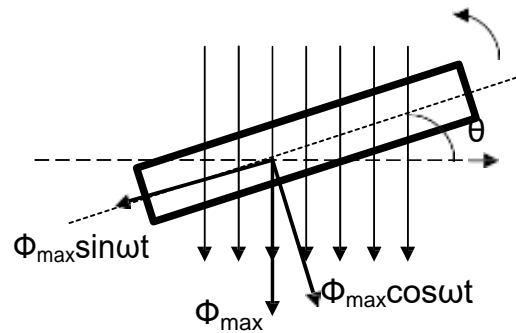

The component of flux acting along the plane of the coil does not induce any flux in the coil. Only the component acting perpendicular to the plane of the coil ie $\Phi_{\max}\cos\omega t$ induces an emf in the coil.

Angular Frequency (ω)

Angular frequency is defined as the number of radians covered in one second (ie the angle covered by the rotating coil). The unit of angular frequency is rad/sec.

$$\omega = \frac{2\pi}{T} = 2\pi f$$

Advantages of AC system over DC system

1. AC voltages can be efficiently stepped up/down using transformer
2. AC motors are cheaper and simpler in construction than DC motors
3. Switchgear for AC system is simpler than DC system

Definition of Alternating Quantity

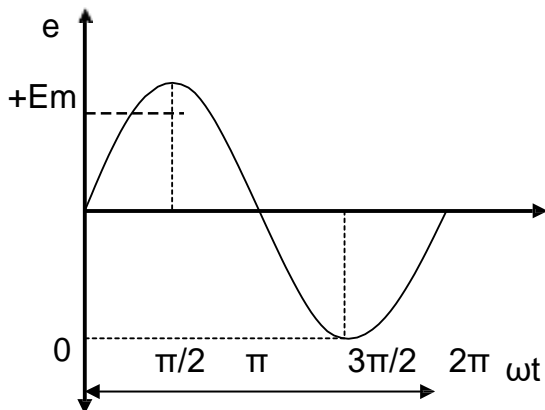

-EmT



An alternating quantity changes continuously in magnitude and alternates in direction at regular intervals of time.

Important terms associated with an alternating quantity are defined below.

Amplitude

It is the maximum value attained by an alternating quantity. Also called as maximum or peak value

Time Period (T)

It is the Time Taken in seconds to complete one cycle of an alternating quantity

Instantaneous Value

It is the value of the quantity at any instant

Frequency (f)

It is the number of cycles that occur in one second. The unit for frequency is Hz or cycles/sec. The relationship between frequency and time period can be derived as follows.

Time taken to complete f cycles = 1 second

Time taken to complete 1 cycle = 1/f second

$$T = 1/f$$

Average Value

The arithmetic average of all the values of an alternating quantity over one cycle is called its average value

Average value = Area under one cycle

Base

$$V_{av} = \frac{1}{2\pi} \int_0^{2\pi} v d(\omega t)$$

For Symmetrical waveforms, the average value calculated over one cycle becomes equal to zero because the positive area cancels the negative area. Hence for symmetrical waveforms, the average value is calculated for half cycle.

Average value = Area under one half cycle

Base

RMS or Effective Value

The effective or RMS value of an alternating quantity is that steady current (dc) which when flowing through a given resistance for a given time produces the same amount of heat produced by the alternating current flowing through the same resistance for the same time.

$$V_{rms} = \sqrt{\frac{1}{2\pi} \int_0^{2\pi} v^2 d(\omega t)}$$

RMS value of a sinusoidal current

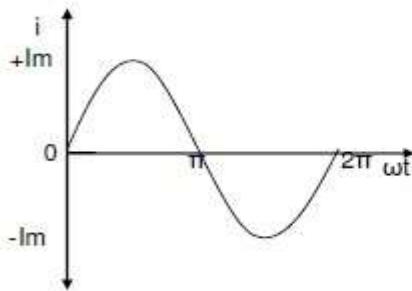

$$i = I_m \sin \omega t$$

$$I_{rms} = \sqrt{\frac{1}{2\pi} \int_0^{2\pi} i^2 d(\omega t)}$$

$$I_{rms} = \sqrt{\frac{1}{\pi} \int_0^{\pi} I_m^2 \sin^2 \omega t d(\omega t)}$$

$$I_{rms} = \frac{I_m}{\sqrt{2}} = 0.707 I_m$$

Form Factor

The ratio of RMS value to the average value of an alternating quantity is known as Form Factor

$$FF = \frac{RMS\ Value}{Average\ Value}$$

Peak Factor or Crest Factor

The ratio of maximum value to the RMS value of an alternating quantity is known as the peak factor

$$PF = \frac{Maximum\ Value}{RMS\ Value}$$



Phasor Representation

An alternating quantity can be represented using

- (i) Waveform
- (ii) Equations
- (iii) Phasor

A sinusoidal alternating quantity can be represented by a rotating line called a **Phasor**. A phasor is a line of definite length rotating in anticlockwise direction at a constant angular velocity

The waveform and equation representation of an alternating current is as shown. This sinusoidal quantity can also be represented using phasors.

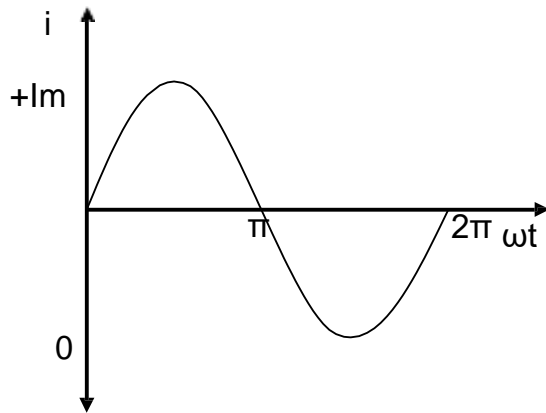

-Im

$$i = I_m \sin \omega t$$

Draw a line OP of length equal to I_m . This line OP rotates in the anticlockwise direction with a uniform angular velocity ω rad/sec and follows the circular trajectory shown in figure. At any instant, the projection of OP on the y-axis is given by $OM = OP \sin \theta = I_m \sin \omega t$. Hence the line OP is the phasor representation of the sinusoidal current

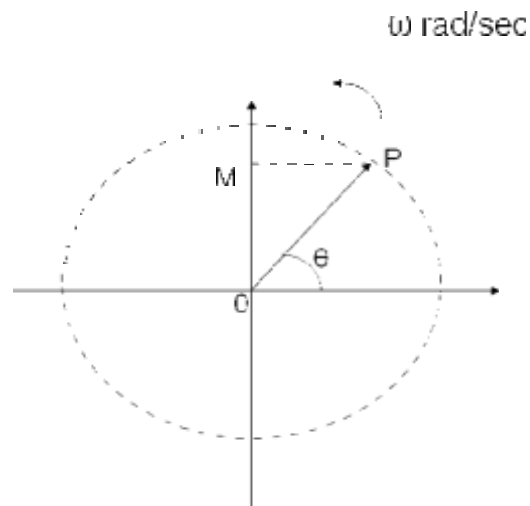

Phase

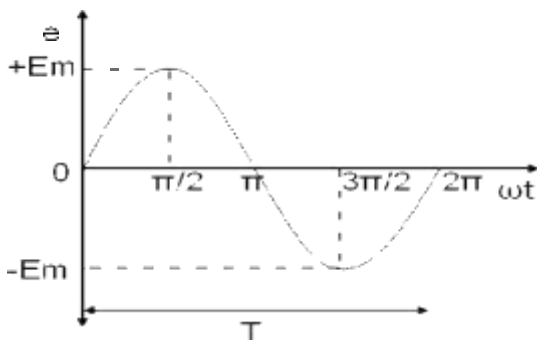

Phase is defined as the fractional part of time period or cycle through which the quantity has advanced from the selected zero position of reference

Phase of $+E_m$ is $\pi/2$ rad or $T/4$ sec
 Phase of $-E_m$ is $3\pi/2$ rad or $3T/4$ sec

Phase Difference

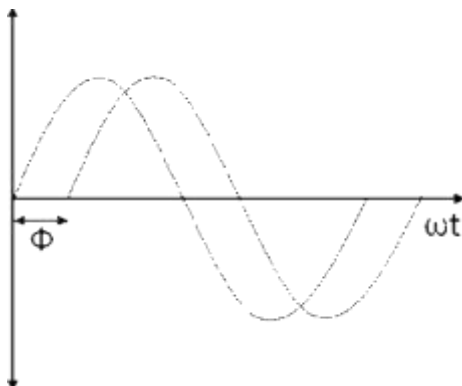



When two alternating quantities of the same frequency have different zero points,

they are said to have a phase difference. The angle between the zero points is the angle of phase difference.

In Phase

Two waveforms are said to be in phase, when the phase difference between them is zero. That is the zero points of both the waveforms are same. The waveform, phasor and equation representation of two sinusoidal quantities which are in phase is as shown. The figure shows that the voltage and current are in phase.

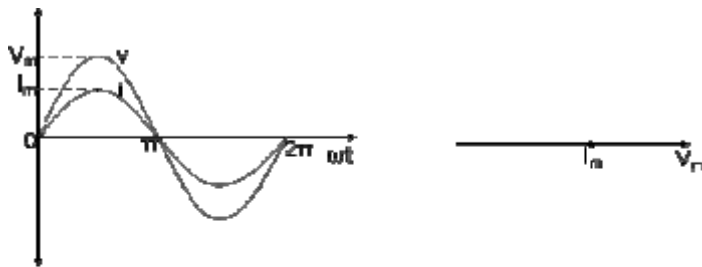

$$v = V_m \sin \omega t$$

$$i = I_m \sin \omega t$$

Lagging

In the figure shown, the zero point of the current waveform is after the zero point of the voltage waveform. Hence the current is lagging behind the voltage. The waveform, phasor and equation representation is as shown.

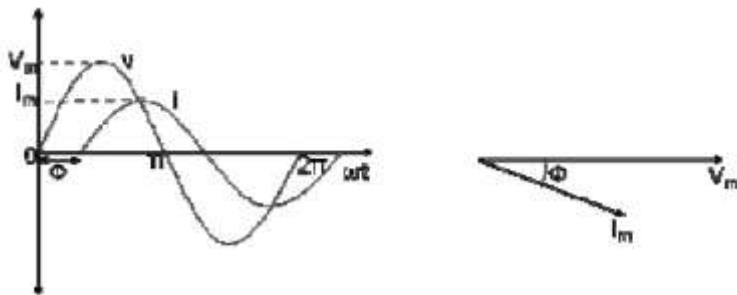

$$v = V_m \sin \omega t$$

$$i = I_m \sin(\omega t - \Phi)$$

Leading



HI-TECH INSTITUTE OF TECHNOLOGY, KHURDA, BHUBANESWAR, ODISHA

In the figure shown, the zero point of the current waveform is before the zero point of

the voltage waveform. Hence the current is leading the voltage. The waveform, phasor and equation representation is as shown.

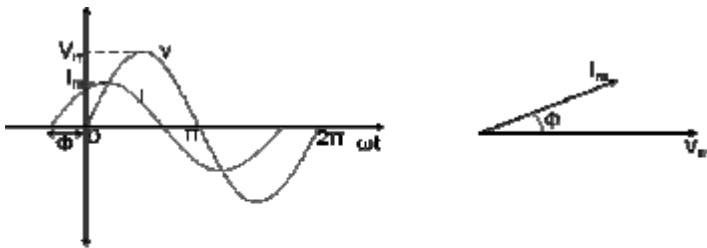

$$v = V_m \sin \omega t$$

$$i = I_m \sin(\omega t + \Phi)$$

AC circuit with a pure resistance

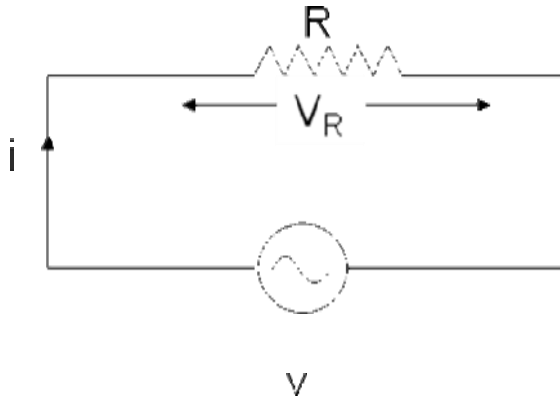

Consider an AC circuit with a pure resistance R as shown in the figure. The alternating voltage v is given by $v = V_m \sin \omega t$

----- (1)

The current flowing in the circuit is i . The voltage across the resistor is given as V_R which is the same as v .

Using ohms law, we can write the following relations

$$i = I_m \sin \omega t \text{ ----- (2)}$$

Where
$$I_m = \frac{V_m}{R}$$

From equation (1) and (2) we conclude that in a pure resistive circuit, the voltage and



HI-TECH INSTITUTE OF TECHNOLOGY, KHURDA, BHUBANESWAR, ODISHA

current are in phase. Hence the voltage and current waveforms and phasors can be

drawn as below.

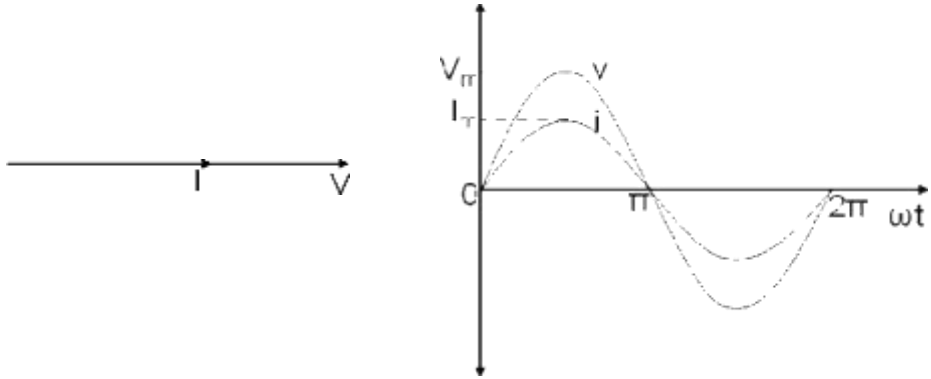

AC circuit with a pure inductance

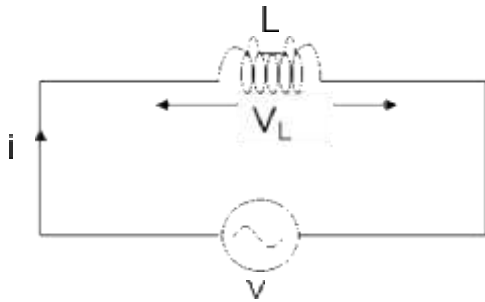

Consider an AC circuit with a pure inductance L as shown in the figure. The alternating voltage v is

given by $v = V_m \sin \omega t$

----- (1)

The current flowing in the circuit is i . The voltage across the inductor is given as V_L which is the same as v .

$$i = I_m \sin(\omega t - \pi/2) \text{----- (2)}$$

From equation (1) and (2) we observe that in a pure inductive circuit, the current lags behind the voltage by 90° . Hence the voltage and current waveforms and phasors can be drawn as below.

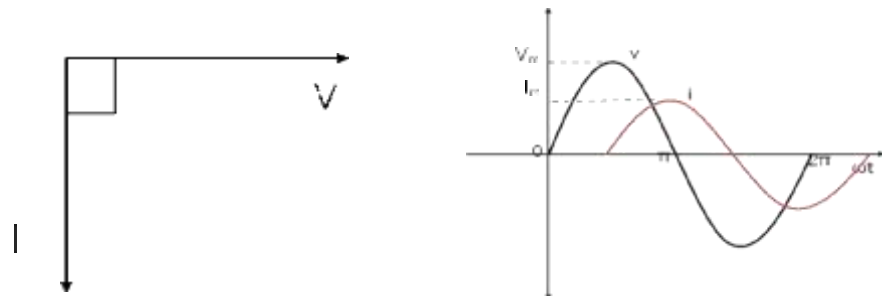



HI-TECH INSTITUTE OF TECHNOLOGY, KHURDA, BHUBANESWAR, ODISHA

The inductive reactance X_L is given as

$$\omega L = 2\pi fL$$

AC circuit with a pure capacitance

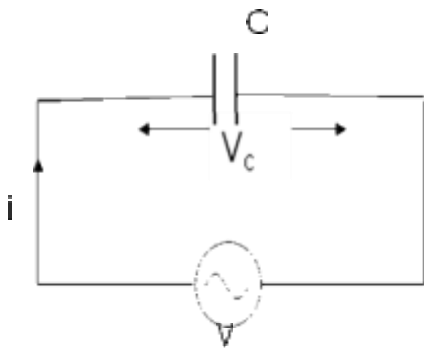

Consider an AC circuit with a pure capacitance C as shown in the figure. The alternating voltage v is given by

$$= V_m \sin \omega t$$

----- (1)

The current flowing in the circuit.

$$i = I_m \sin(\omega t + \pi/2)$$

----- (2)

From equation (1) and (2) we observe that in a pure capacitive circuit, the current leads the voltage by 90° . Hence the voltage and current waveforms and phasors can be drawn as below.

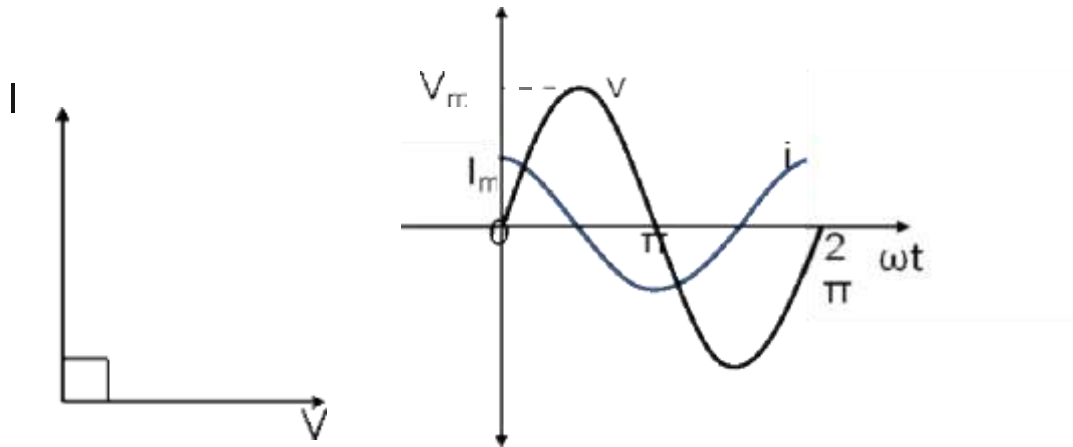

Capacitive reactance

The capacitive reactance X_C is given as

$$X_C = \frac{1}{\omega C} = \frac{1}{2\pi f C}$$

$$I_m = \frac{V_m}{X_C}$$

It is equivalent to resistance in a resistive circuit. The unit is ohms (Ω)

R-L Series circuit

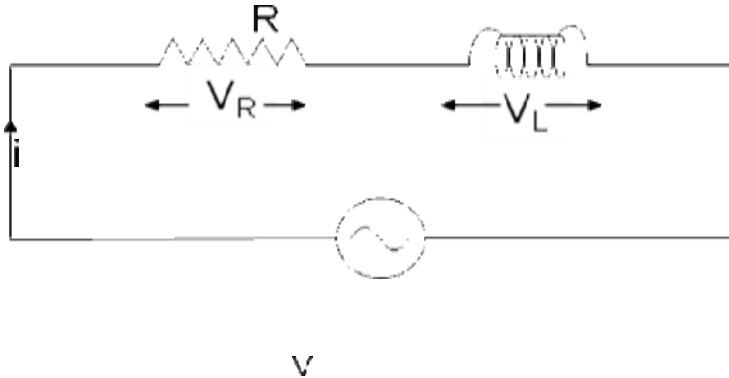

Consider an AC circuit with a resistance R and an inductance L connected in series as shown in the figure. The alternating voltage v is given by

$$v = V_m \sin \omega t$$

The current flowing in the circuit is i . The voltage across the resistor is V_R and that across the inductor is V_L .

$V_R = IR$ is in phase with I

$V_L = IX_L$ leads current by 90 degrees

With the above information, the phasor diagram can be drawn as shown.

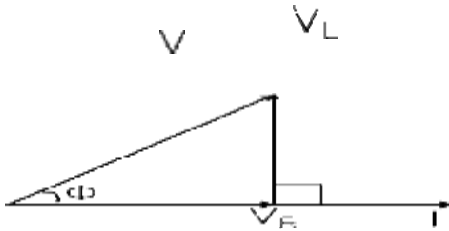

The current I is taken as the reference phasor. The voltage V_R is in phase with I and the voltage V_L leads the current by 90° . The resultant voltage V can be drawn as shown in the figure. From the phasor diagram we observe that the voltage leads the current by an angle Φ or in other words the current lags behind the voltage by an angle Φ .

The waveform and equations for an RL series circuit can be drawn as below.

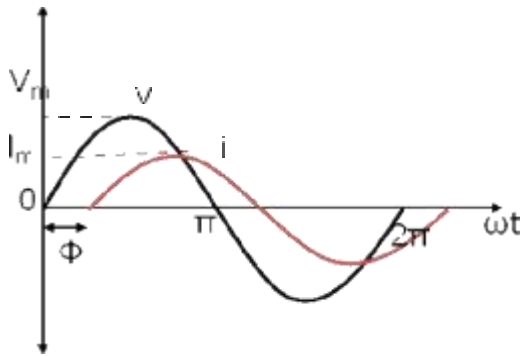

$$V = V_m \sin \omega t$$

$$I = I_m \sin(\omega t - \Phi)$$

From the phasor diagram, the expressions for the resultant voltage V and the angle Φ can be derived as follows.

$$V = \sqrt{V_R^2 + V_L^2}$$

$$V_R = IR$$

$$V_L = IX_L$$

$$V = \sqrt{(IR)^2 + (IX_L)^2}$$

$$V = I \sqrt{R^2 + X_L^2}$$

$$V = IZ$$

Where impedance $Z = \sqrt{R^2 + X_L^2}$

The impedance in an AC circuit is similar to a resistance in a DC circuit. The unit for impedance is ohms (Ω).

Impedance Triangle

We can derive a triangle called the impedance triangle from the phasor diagram of an RL series circuit as shown

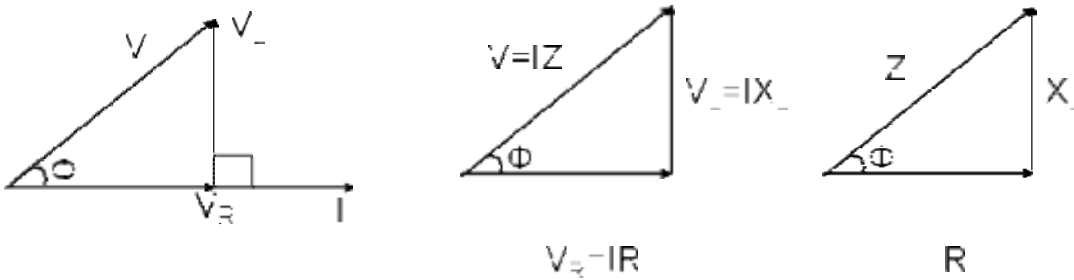

The impedance triangle is right angled triangle with R and X_L as two sides and impedance as the hypotenuse. The angle between the base and hypotenuse is Φ .

Power

In an AC circuit, the various powers can be classified as

1. Real or Active power
2. Reactive power
3. Apparent power

Real or active power in an AC circuit is the power that does useful work in the circuit. Reactive power flows in an AC circuit but does not do any useful work. Apparent power is the total power in an AC circuit.

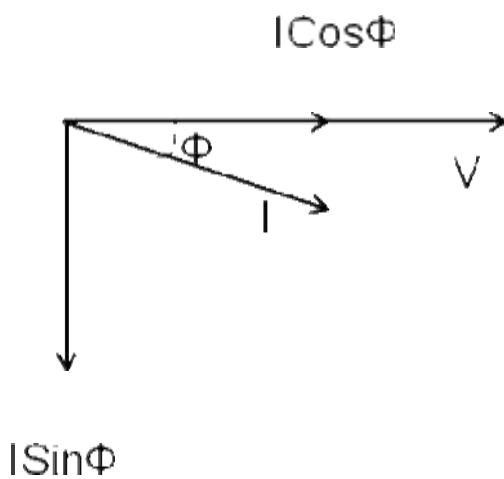



From the phasor diagram of an RL series circuit, the current can be divided into two components. One component along the voltage $I \cos \Phi$, that is called as the active component of current and another component perpendicular to the voltage $I \sin \Phi$ that is called as the reactive component of current.

Real Power

The power due to the active component of current is called as the active power or real power. It is denoted by P.

$$P = V \times I \cos \Phi = I^2 R$$

Real power is the power that does useful work. It is the power that is consumed by the resistance. The unit for real power is Watt (W).

Reactive Power

The power due to the reactive component of current is called as the reactive power. It is denoted by Q.

$$Q = V \times I \sin \Phi = I^2 X_L$$

Reactive power does not do any useful work. It is the circulating power in the L and C components. The unit for reactive power is Volt Amperes Reactive (VAR).

Apparent Power

The apparent power is the total power in the circuit. It is denoted by S.

$$S = V \times I = I^2 Z$$

$$S = \sqrt{P^2 + Q^2}$$

The unit for apparent power is Volt Amperes (VA).

Power Triangle

From the impedance triangle, another triangle called the power triangle can be derived as shown.

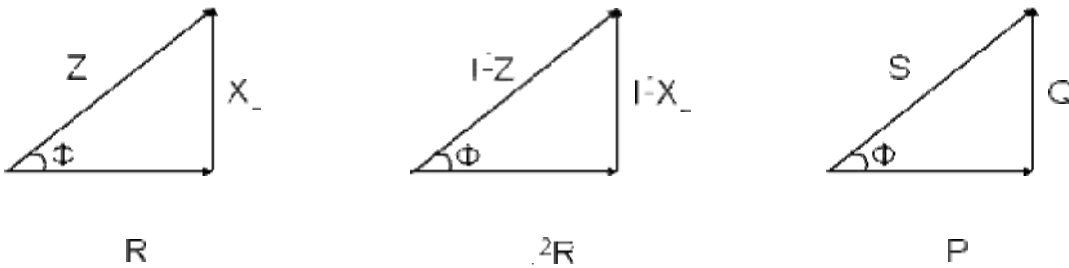

The power triangle is right angled triangle with P and Q as two sides and S as the hypotenuse. The angle between the base and hypotenuse is Φ . The power triangle enables us to calculate the following things.

1. Apparent power $S = \sqrt{P^2 + Q^2}$

$$\cos\Phi = \frac{P}{S} = \frac{\text{Real Power}}{\text{Apparent Power}}$$

2. Power Factor $\frac{P}{S}$

The power Factor in an AC circuit can be calculated by any one of the following methods

- ❖ Cosine of angle between V and I
- ❖ Resistance/Impedance R/Z
- ❖ Real Power/Apparent Power P/S

Phasor algebra in a RL series circuit

$$\underline{V} = V + j0 = V\angle 0^\circ$$

$$\underline{Z} = R + jX_L = Z\angle\Phi$$



HI-TECH INSTITUTE OF TECHNOLOGY, KHURDA, BHUBANESWAR, ODISHA

$$I = \frac{V}{Z} = \frac{V}{Z}$$

$$\angle -\Phi$$

$$\mathcal{S} = VI^* = P + jQ$$

R-C Series circuit

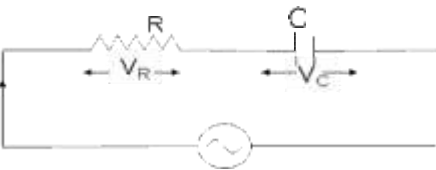

i

v

Consider an AC circuit with a resistance R and a capacitance C connected in series as shown in the figure. The alternating voltage v is given by

$$v = V_m \sin \omega t$$

The current flowing in the circuit is i . The voltage across the resistor is V_R and that across the capacitor is V_C .

$V_R = IR$ is in phase with I

$V_C = IX_C$ lags behind the current by 90 degrees

With the above information, the phasor diagram can be drawn as shown.

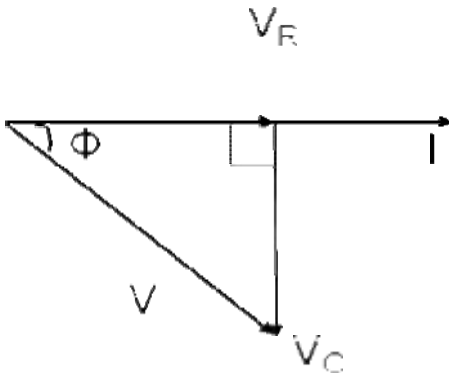

The current I is taken as the reference phasor. The voltage V_R is in phase with I and the voltage V_C lags behind the current by 90° . The resultant voltage V can be drawn as shown in the figure. From the phasor diagram we observe that the voltage lags behind the current by an angle Φ or in other words the current leads the voltage by an angle Φ .

The waveform and equations for an RC series circuit can be drawn as below.

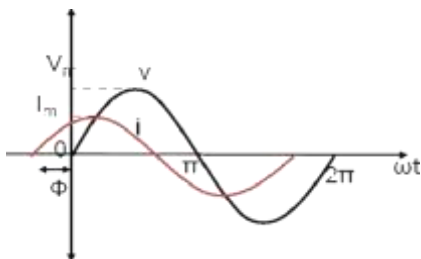

$$V = V_m \sin \omega t$$

$$I = I_m \sin(\omega t + \Phi)$$



From the phasor diagram, the expressions for the resultant voltage V and the angle Φ

can be derived as follows.

$$V = \sqrt{V_R^2 + V_C^2}$$

$$V_R = IR$$

$$V_C = IX_C$$

$$V = \sqrt{(IR)^2 + (IX_C)^2}$$

$$V = I \sqrt{R^2 + X_C^2}$$

$$V = IZ$$

Where impedance $Z = \sqrt{R^2 + X_C^2}$

Average power

$$P = VI \cos \phi$$

Hence the power in an RC series circuit is consumed only in the resistance. The capacitance does not consume any power.

Impedance Triangle

We can derive a triangle called the impedance triangle from the phasor diagram of an RC series circuit as shown

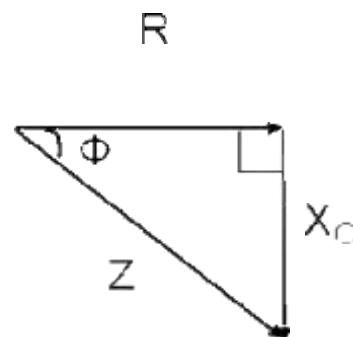
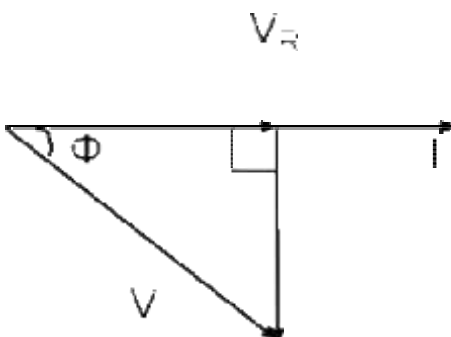

Phasor algebra for RC series circuit

$$\bar{V} = V + j0 = V \angle 0^\circ$$

$$\bar{Z} = R - jX_C = Z \angle -\Phi$$

$$\bar{I} = \frac{\bar{V}}{\bar{Z}} = \frac{V}{Z} \angle +\Phi$$

R-L-C Series circuit

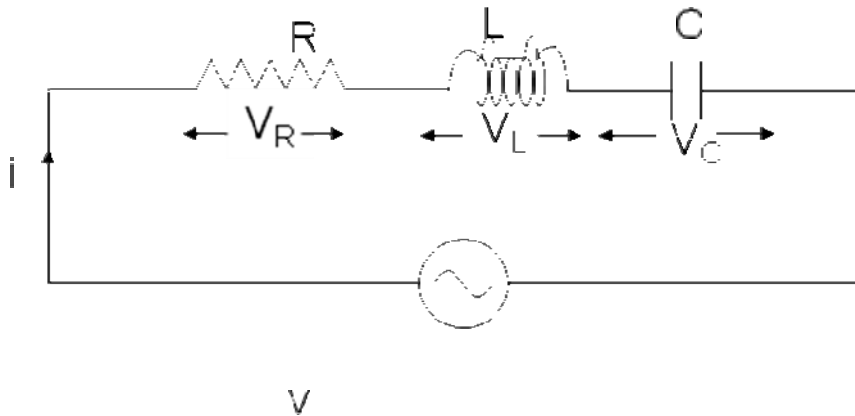

Consider an AC circuit with a resistance R , an inductance L and a capacitance C connected in series as shown in the figure. The alternating voltage v is given by

$$v = V_m \sin \omega t$$

The current flowing in the circuit is i . The voltage across the resistor is V_R , the voltage across the inductor is V_L and that across the capacitor is V_C .

$V_R = IR$ is in phase with I

$V_L = IX_L$ leads the current by 90 degrees

$V_C = IX_C$ lags behind the current by 90 degrees

With the above information, the phasor diagram can be drawn as shown. The current I is taken as the reference phasor. The voltage V_R is in phase with I , the voltage V_L leads the current by 90° and the voltage V_C lags behind the current by 90° . There are two cases that can occur $V_L > V_C$ and $V_L < V_C$ depending on the values of X_L and X_C . And hence there are two possible phasor diagrams. The phasor $V_L - V_C$ or $V_C - V_L$ is drawn and then the resultant voltage V is drawn.

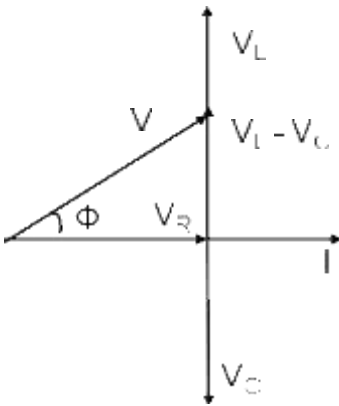

$$V_L > V_C$$

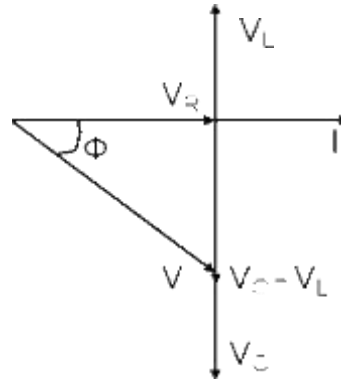

$$V_L < V_C$$

From the phasor diagram we observe that when $V_L > V_C$, the voltage leads the current by an angle Φ or in other words the current lags behind the voltage by an angle Φ . When $V_L < V_C$, the voltage lags behind the current by an angle Φ or in other words the current leads the voltage by an angle Φ .

From the phasor diagram, the expressions for the resultant voltage V and the angle Φ can be derived as follows.

$$V = \sqrt{V_R^2 + (V_L - V_C)^2}$$

$$V = \sqrt{(IR)^2 + (IX_L - IX_C)^2}$$

Where impedance $Z = \frac{V}{I} = \sqrt{R^2 + (X_L - X_C)^2}$

From the expression for phase angle, we can derive the following three cases

Case (i): When $X_L > X_C$

The phase angle Φ is positive and the circuit is inductive. The circuit behaves like a series RL circuit.

Case (ii): When $X_L < X_C$

The phase angle Φ is negative and the circuit is capacitive. The circuit behaves like a series RC circuit.

Case (iii): When $X_L = X_C$

The phase angle $\Phi = 0$ and the circuit is purely resistive. The circuit behaves like a pure resistive circuit.

The voltage and the current can be represented by the following equations. The angle Φ is positive or negative depending on the circuit elements.

$$V = V_m \sin \omega t$$

$$I = I_m \sin(\omega t \pm \Phi)$$

Average power

$$P = VI \cos \phi$$

$$P = (IZ) \times I \times \frac{R}{Z}$$

$$P = I^2 R$$

Hence the power in an RLC series circuit is consumed only in the resistance. The inductance and the capacitance do not consume any power.

Phasor algebra for RLC series circuit

$$\underline{V} = V + j0 = V \angle 0^\circ$$

$$\underline{Z} = R + j(X_L - X_C) = Z \angle \Phi$$

$$\underline{I} = \frac{\underline{V}}{\underline{Z}} = \frac{V}{Z} \angle -\Phi$$



UNIT-III

Transformers

INTRODUCTION

Transformer is a static device which transfers electrical energy from one electrical circuit to another electrical circuit without change in frequency through magnetic medium. The winding which receives energy is called primary winding and the winding which delivers energy to the load is called secondary winding.

Based on the voltage levels transformers are classified into two types

- i. Step down transformer
- ii. Step up transformer.

CONSTRUCTION

CORE-TYPE AND SHELL-TYPE CONSTRUCTION

Depending upon the manner in which the primary and secondary windings are placed on the core, and the shape of the core, there are two types of transformers, called (a) core type, and (b) shell type. In core type transformers, the windings are placed in the form of concentric cylindrical coils placed around the vertical limbs of the core. The low-voltage (LV) as well as the high-voltage (HV) winding are made in two halves, and placed on the two limbs of core. The LV winding is placed next to the core for economy in insulation cost. Figure a shows the cross-section of the arrangement. In the shell type transformer, the primary and secondary windings are wound over the central limb of a three-limb core as shown in Figure b. The HV and LV windings are split into a number of sections, and the sections are interleaved or sandwiched i.e. the sections of the HV and LV windings are placed alternately.

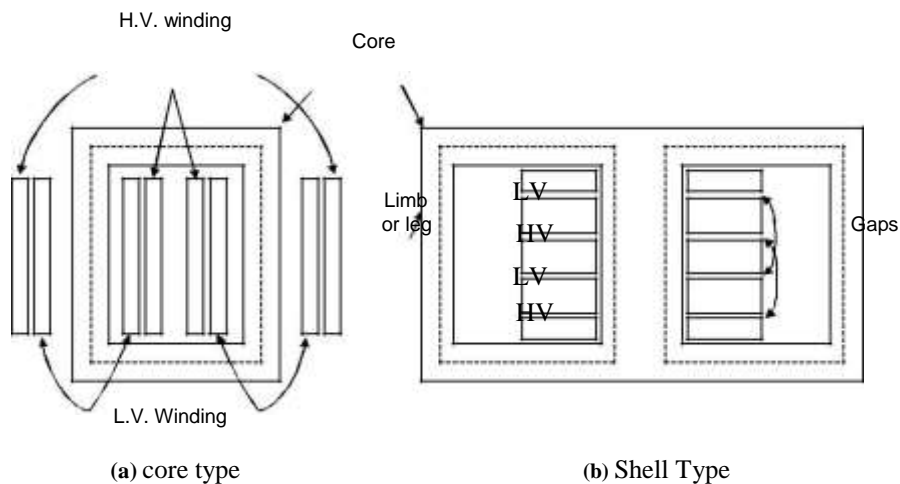

CORE

The core is built-up of thin steel laminations insulated from each other. This helps in reducing the eddy current losses in the core, and also helps in construction of the transformer. The steel used for core is of high silicon content, sometimes heat treated to produce a high permeability and low hysteresis loss. The material commonly used for core

is CRGO (Cold Rolled Grain Oriented) steel.

Conductor material used for windings is mostly copper. However, for small distribution transformer aluminium is also sometimes used. The conductors, core and whole windings are insulated using various insulating materials depending upon the voltage.

INSULATING OIL

In oil-immersed transformer, the iron core together with windings is immersed in insulating oil. The insulating oil provides better insulation, protects insulation from moisture and transfers the heat produced in core and windings to the atmosphere. The transformer oil should possess the following quantities:

- (a) High dielectric strength,
- (b) Low viscosity and high purity,
- (c) High flash point, and
- (d) Free from sludge.

Transformer oil is generally a mineral oil obtained by fractional distillation of crude oil.

TANK AND CONSERVATOR

The transformer tank contains core wound with windings and the insulating oil. In large transformers small expansion tank is also connected with main tank is known as conservator. Conservator provides space when insulating oil expands due to heating. The transformer tank is provided with tubes on the outside, to permit circulation of oil, which aids in cooling. Some additional devices like breather and Buchholz relay are connected with main tank.

Buchholz relay is placed between main tank and conservator. It protects the transformer under extreme heating of transformer winding. Breather protects the insulating oil from moisture when the cool transformer sucks air inside. The silica gel filled breather absorbs moisture when air enters the tank. Some other necessary parts are connected with main tank like, Bushings, Cable Boxes, Temperature gauge, Oil gauge, Tapings, etc.

WORKING PRINCIPLE

In its simplest form a single-phase transformer consists of two windings, wound on an iron core one of the windings is connected to an ac source of supply f . The source supplies a current to this winding (called primary winding) which in turn produces a flux in the iron core. This flux is alternating in nature. If the supplied voltage has a frequency f , the flux in the core also alternates at a frequency f . The alternating flux linking with the second winding, induces a voltage E_2 in the second winding (according to Faraday's law). [Note that this alternating flux linking with primary winding will also induce a voltage in the primary winding, denoted as E_1 . Applied voltage V_1 is very nearly equal to E_1]. If the number of turns in the primary and secondary windings is N_1 and N_2 respectively, we shall see later in this unit that $E_1/N_1 = E_2/N_2$. The load is connected across the secondary winding, between the terminals a_1, a_2 . Thus, the load can be supplied at a voltage higher or lower than the supply

voltage, depending upon the ratio N_1/N_2 .

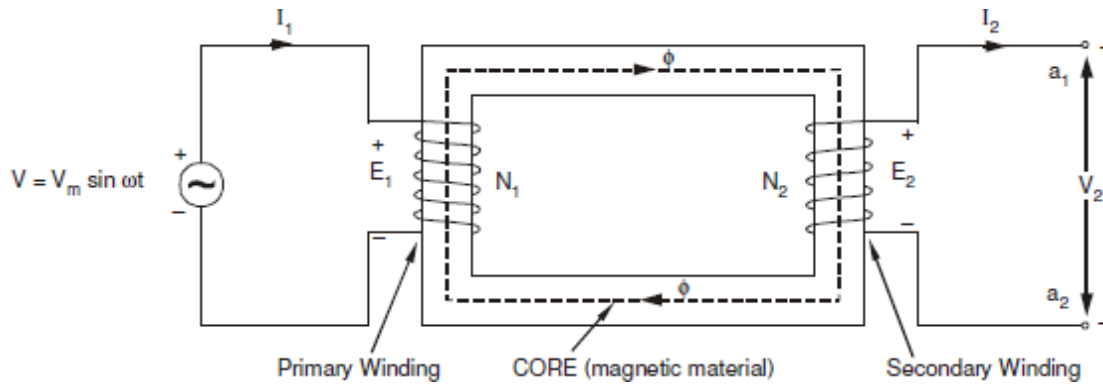

IDEAL TRANSFORMER

Under certain conditions, the transformer can be treated as an ideal transformer. The assumptions necessary to treat it as an ideal transformer are :

- (a) Primary and secondary windings have zero resistance. This means that ohmic loss ($I^2 R$ loss), and resistive voltage drops in windings are zero.
- (b) There is no leakage flux, i.e. the entire flux is mutual flux that links both the primary and secondary windings.
- (c) Permeability of the core is infinite this means that the magnetizing current needed for establishing the flux is zero.
- (d) Core loss (hysteresis as well as eddy current losses) are zero.

IDEAL TRANSFORMER ON NO LOAD

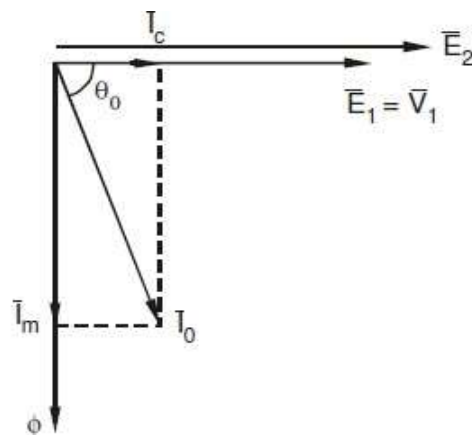

(a) Phasor Diagram at No Load

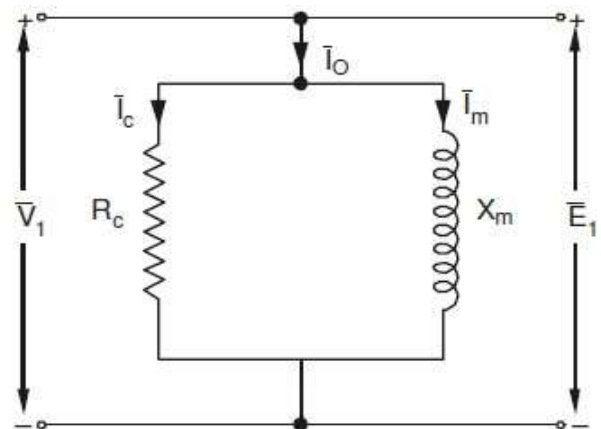

(b) Equivalent Circuit at No Load

IDEAL TRANSFORMER ON LOAD

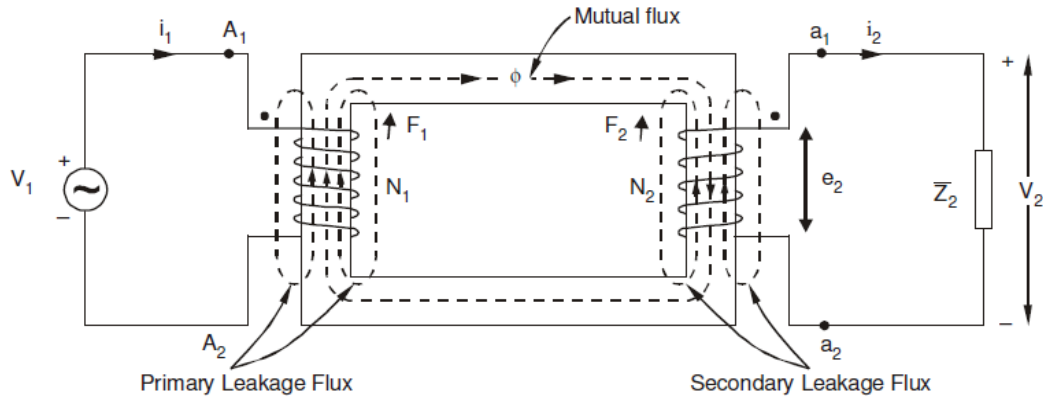

$$V_1/V_2 = N_1/N_2 = I_1/I_2$$

EQUIVALENT CIRCUIT OF REAL TRANSFORMER

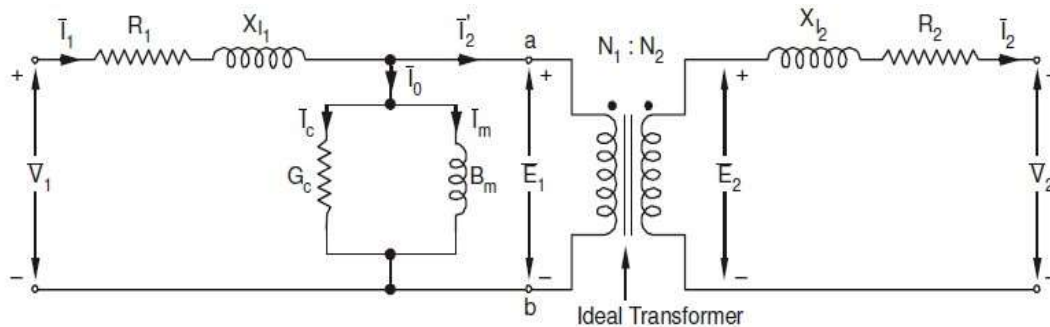

REGULATION OF TRANSFORMER

Voltage regulation of a transformer is defined as the drop in the magnitude of load voltage (or secondary terminal voltage) when load current changes from zero to full load value. This is expressed as a fraction of secondary rated voltage

(%) Regulation = (Secondary terminal voltage at no load – Secondary terminal voltage at any load)/ secondary rated voltage.

$$\text{Percentage voltage regulation} = (V - E_0) * 100 / V$$

LOSSES AND EFFICIENCY OF TRANSFORMER

A transformer doesn't contain any rotating part so it is free from friction and windage losses.

In transformer the losses occur in iron parts as well as in copper coils. In iron core the losses are sum of hysteresis and eddy current losses. The hysteresis losses are

$$P_h \propto f B_{\max}^x \text{ and eddy current loss is equal to } P_e \propto f^2 B_{\max}.$$

Where “ f ” is frequency “ B_{\max} ” is maximum flux density.

IRON LOSSES OR CORE LOSSES

To minimize hysteresis loss in transformer, we use Cold Rolled Grain Oriented (CRGO) silicon steel to build up the iron core.

EDDY CURRENT LOSS

When the primary winding variable flux links with iron core then it induces some EMF on the surface of core. The magnitude of EMF is different at various points in core. So, there is current between different points in Iron Core having unequal potential.

These currents are known as eddy currents. $I^2 R$ loss in iron core is known as eddy current loss. These losses depend on thickness of core. To minimize the eddy current losses we use the Iron Core which is made of laminated sheet stampings. The thickness of stamping is around 0.5 mm.

COPPER LOSSES

In a transformer the primary and secondary winding currents increase with increases in load. Due to these currents there is some $I^2 R$ losses. These are known as copper losses or ohmic losses. The total $I^2 R$ loss in both windings at rated or full load current is equal to $I_1^2 R_1 = I_2^2 R_2$.

EFFICIENCY OF SINGLE PHASE TRANSFORMER

$$\text{Efficiency } (\eta) = \frac{\text{output power}}{\text{input power}} \\ = \frac{\text{input power} - \text{total losses}}{\text{input power}}$$

$$\text{Alternatively } \eta = \frac{\text{output power}}{\text{output power} + \text{total losses}}$$

In a transformer, if P_i is the iron loss, and P_c is the copper loss at full load (when the load current is equal to the rated current of the transformer, the total losses in the transformer are $P_i + P_c$. In any transformer, copper losses are variable and iron losses are fixed.

When the load on transformer is x times full load then

$$\eta = \frac{x V_2 I_2 \cos \phi}{x V_2 I_2 \cos \phi + P_i + x^2 P_c}$$

$$\text{or } \eta = \frac{x \text{ KVA } \cos \phi}{x \text{ KVA } \cos \phi + P_i + x^2 P_c}$$

OPEN CIRCUIT TEST

Practically we can determine the iron losses by performing the open circuit test and also the core loss components of equivalent circuit.

We perform open circuit test in low voltage winding in transformer keeping the high voltage winding open. The circuit is connected as shown in Figure. The instruments are connected on the LV side. The advantage of performing the test from LV side is that the test can be performed at rated voltage.

When we apply rated voltage then watt meter shows iron losses [There is some copper loss but this is negligible when compared to iron loss]. The ammeter shows no load current I_0 which is very small [2-5 % of rated current]. Thus, the drops in R_1 and X_{l1} can be neglected.

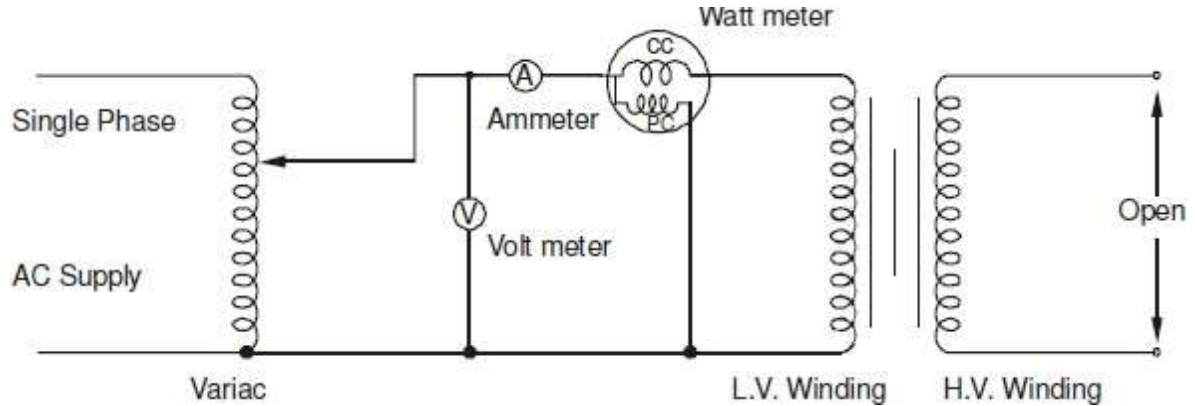

We have $W_0 = \text{iron loss}$
 $I_0 = \text{no load current}$
 Then $\cos \phi = \frac{W_0}{V_i I_0}$
 So $I_e = I_0 \cos \phi$
 And $I_m = I_0 \sin \phi$
 $R_0 = V_i / I_e$
 $X_0 = V_i / I_m$

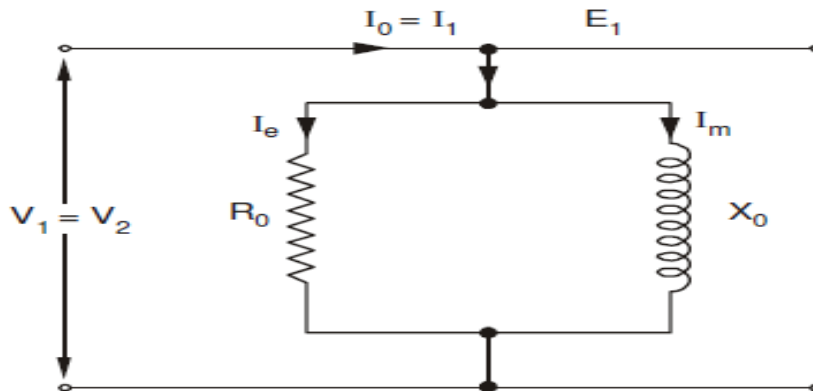

SHORT CIRCUIT TEST

From short circuit test we can determine copper losses and also the winding components of equivalent circuit. It's an indirect method to find out the copper losses. To perform this test, we apply a reduced voltage to the primary winding through instruments keeping LV winding short circuited. The connections are shown in Figure. We need to apply only 5-10% of rated voltage to primary to circulate rated current in the primary and secondary winding. The applied voltage is adjusted so that the ammeter shows rated current of the winding. Under this condition, the wattmeter reading shows the copper losses of the transformer. Because of low value of applied voltage, iron losses, are very small and can be neglected.

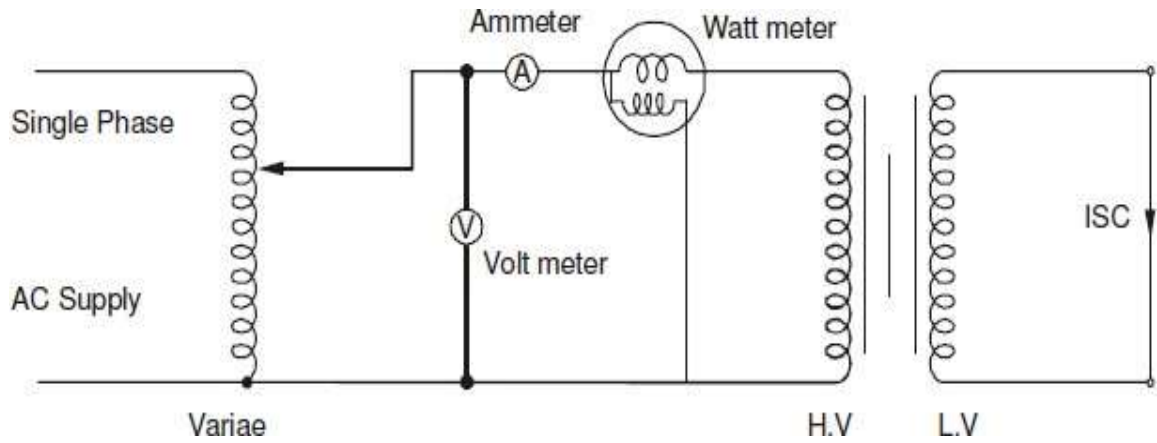

Connection diagram for short circuit test

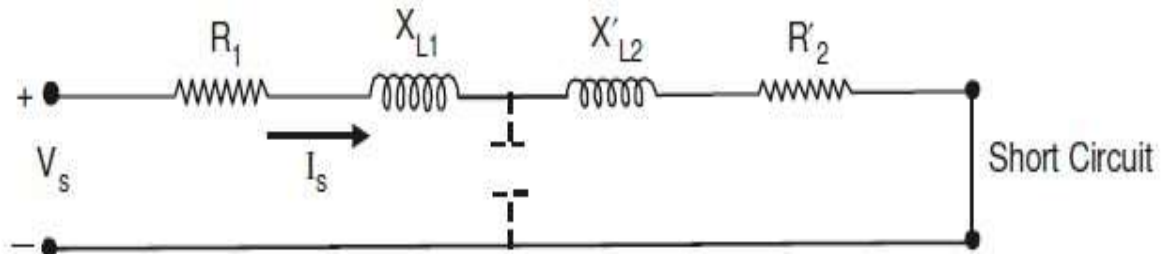

Equivalent circuit under short circuit

At a rated current watt meter shows full load copper loss. We have

$$\begin{aligned}
 W_{sc} &= \text{copper loss} \\
 I_{sc} &= \text{full load current} \\
 V_{sc} &= \text{supply voltage} \\
 R_{eq} &= W_{sc} / I_{sc}^2 \\
 Z_{eq} &= V_{sc} / I_{sc} \\
 X_{eq} &= \sqrt{Z_{eq}^2 - R_{eq}^2}
 \end{aligned}$$

and equivalent impedance

So we calculate equivalent reactance. These R_{eq} and X_{eq} are equivalent resistance and reactance of both windings referred in HV side. These are known as equivalent circuit resistance and reactance.



UNIT-IV

DC GENERATOR

Introduction:

The electrical machines deals with the energy transfer either from mechanical to electrical form or from electrical to mechanical form, this process is called electromechanical energy conversion. An electrical machine which converts mechanical energy into electrical energy is called an electric generator while an electrical machine which converts electrical energy into the mechanical energy is called an electric motor. A DC generator is built utilizing the basic principle that emf is induced in a conductor when it cuts magnetic lines of force. A DC motor works on the basic principle that a current carrying conductor placed in a magnetic field experiences a force.

Working principle:

All the generators work on the principle of dynamically induced emf. The change in flux associated with the conductor can exist only when there exists a relative motion between the

conductor and the flux. The relative motion can be achieved by rotating the conductor w.r.t flux or by rotating flux w.r.t conductor. So, a voltage gets generated in a conductor as long as there exists a relative motion between conductor and the flux. Such an induced emf which is due to physical movement of coil or conductor w.r.t flux or movement of flux w.r.t coil or conductor is called dynamically induced emf. Whenever a conductor cuts magnetic flux, dynamically induced emf is produced in it according to Faraday's laws of Electromagnetic Induction. This emf causes a current to flow if the conductor circuit is closed. In a practical generator, the conductors are rotated to cut the magnetic flux, keeping flux stationary. To have a large voltage as output, a number of conductors are connected together in a specific manner to form a winding. The winding is called armature winding of a dc machine and the part on which this winding is kept is called armature of the dc machine. The magnetic field is produced by a current carrying winding which is called field winding. The conductors placed on the armature are rotated with the help of some external device. Such an external device is called a prime mover. The commonly used prime movers are diesel engines, steam engines, steam turbines, water turbines etc. The purpose of the prime mover is to rotate the electrical conductor as required by Faraday's laws. The direction of induced emf can be obtained by using Fleming's right hand rule. The magnitude of induced emf $= e = BLV \sin \theta = E_m \sin \theta$. The nature of the induced emf for a conductor rotating in the magnetic field is alternating. As conductor rotates in a magnetic field, the voltage component at various positions is different. Hence the basic nature of induced emf in the armature winding in case of dc generator is alternating. To get dc output which is unidirectional, it is necessary to rectify the alternating induced emf. A device which is used in dc generator to convert alternating induced emf to unidirectional dc emf is called commutator.

Construction of DC machines: A D. C. machine consists of two main parts

1. Stationary part: It is designed mainly for producing a magnetic flux.
2. Rotating part: It is called the armature, where mechanical energy is converted into electrical (electrical generate) or conversely electrical energy into mechanical (electric into)

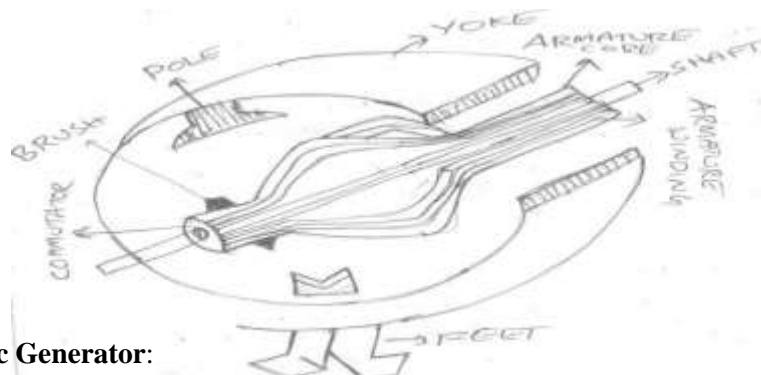

Parts of a Dc Generator:

The stationary parts and rotating parts are separated from each other by an air gap. The stationary part of a D. C. machine consists of main poles, designed to create the magnetic flux, commutating poles interposed between the main poles and designed to ensure spark less operation of the brushes at the commutator and a frame / yoke. The armature is a cylindrical body rotating in the space between the poles and comprising a slotted armature core, a winding inserted in the armature core slots, a commutator and brush

Yoke:

It saves the purpose of outermost cover of the dc machine so that the insulating materials get protected from harmful atmospheric elements like moisture, dust and various gases like SO₂, acidic fumes etc. It provides mechanical support to the poles. It forms a part of the magnetic circuit. It provides a path of low reluctance for magnetic flux. Choice of material: To provide low reluctance path, it must be made up of some magnetic material. It is prepared by using cast iron because it is the cheapest. For large machines rolled steel or cast steel, is used which provides high permeability i.e., low reluctance and gives good mechanical strength.

Poles: Each pole is divided into two parts

a) pole core

b) pole shoe

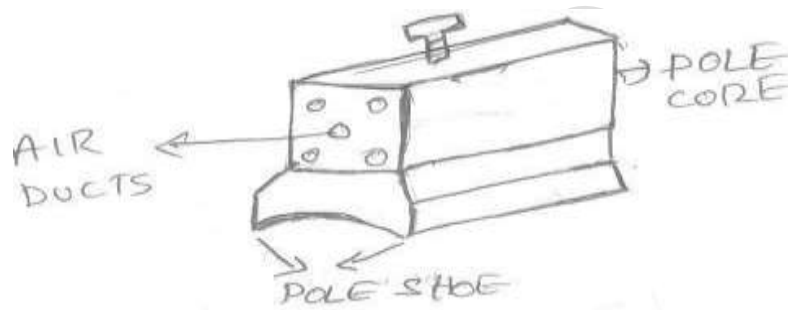

Pole core basically carries a field winding which is necessary to produce the flux. It directs the flux produced through air gap to armature core to the next pole. Pole shoe enlarges the area of armature core to come across the flux, which is necessary to produce larger induced emf. To achieve this, pole core has been given a particular shape. Choice of material: It is made up of magnetic material like cast iron or cast steel. As it requires a definite shape and size, laminated construction is used. The laminations of required size and shape are stamped together to get a pole which is then bolted to yoke.

Armature: It is further divided into two parts namely,

(1) Armature core

(2) Armature winding.

Armature core is cylindrical in shape mounted on the shaft. It consists of slots on its periphery and the air ducts to permit the air flow through armature which serves cooling purpose.

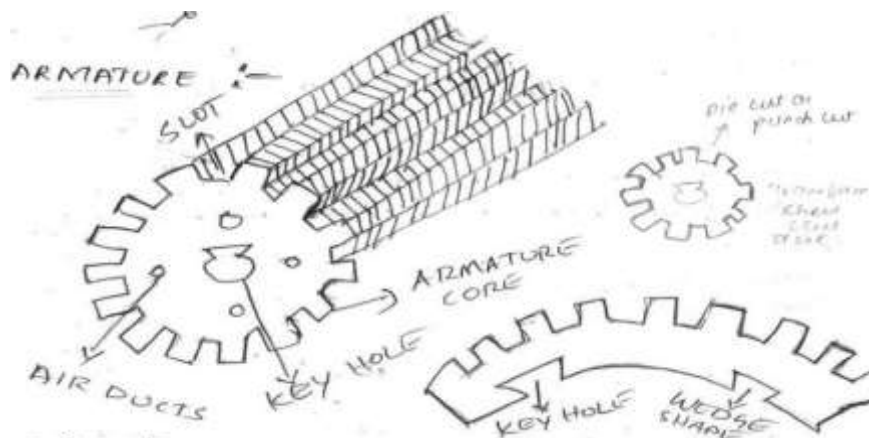

Armature core provides house for armature winding i.e., armature conductors. To provide a path of low reluctance path to the flux it is made up of magnetic material like cast iron or cast steel. Choice of material: As it has to provide a low reluctance path to the flux, it is made up of magnetic material like cast iron or cast steel. It is made up of laminated construction to keep eddy current loss as low as possible. A single circular lamination used for the construction of the armature core is shown below.

Armature winding:

Armature winding is nothing but the inter connection of the armature conductors, placed in the slots provided on the armature core. When the armature is rotated, in case of generator magnetic flux gets cut by armature conductors and emf gets induced in them. Generation of emf takes place in the armature winding in case of generators. To carry the current supplied in case of dc motors. To do the useful work in the external circuit.

Choice of material: As armature winding carries entire current which depends on external load, it has to be made up of conducting material, which is copper.

Field winding:

The field winding is wound on the pole core with a definite direction.

Functions: To carry current due to which pole core on which the winding is placed behaves as an electromagnet, producing necessary flux. As it helps in producing the magnetic field i.e. exciting the pole as electromagnet it is called '**Field winding**' or '**Exciting winding**'.

Choice of material: As it has to carry current it should be made up of some conducting material like the aluminum or copper. But field coils should take any type of shape should bend easily, so copper is the proper choice. Field winding is divided into various coils called as field coils. These are connected in series with each other and wound in such a direction around pole cores such that alternate N and S poles are formed.

Commutator: The rectification in case of dc generator is done by device called as commutator.

Functions: To facilitate the collection of current from the armature conductors. To convert internally developed alternating emf to in directional (dc) emf. To produce unidirectional torque in case of motor.

Choice of material: As it collects current from armature, it is also made up of copper segments. It is cylindrical in shape and is made up of wedge shaped segments which are insulated from each other by thin layer of mica.

Brushes and brush gear: Brushes are stationary and rest on the surface of the Commutator. Brushes are rectangular in shape. They are housed in brush holders, which are usually of box type. The brushes are made to press on the commutator surface by means of a spring, whose tension can be adjusted with the help of lever. A flexible copper conductor called pigtail is used to connect the brush to the external circuit.

Functions: To collect current from commutator and make it available to the stationary external circuit. Choice of material: Brushes are normally made up of soft material like carbon.

Bearings: Ball-bearings are usually used as they are more reliable. For heavy duty machines, roller bearings are preferred.

Types of armature winding

Armature conductors are connected in a specific manner called as armature winding and according to the way of connecting the conductors; armature winding is divided into two types.

Lap winding: In this case, if connection is started from conductor in slot 1 then the connections overlap each other as winding proceeds, till starting point is reached again.

There is overlapping of coils while proceeding. Due to such connection, the total number of conductors get divided into „P“ number of parallel paths, where

P = number of poles in the machine.

Large number of parallel paths indicate high current capacity of machine hence lap winding is pertained for high current rating generators.

Wave winding: In this type, winding always travels ahead avoiding over lapping. It travels like a progressive wave hence called wave winding. Both coils starting from slot 1 and slot 2 are progressing in wave fashion. Due to this type of connection, the total number of conductors get divided into two number of parallel paths always, irrespective of number of poles of machine.

EMF equation

$$\text{EMF generated/path} = \phi PN/60 \text{ (Z/P)} = \phi ZN/60$$

Z = total number of armature conductors.

= number of slots x number of conductors/slot

N = armature rotation in revolutions (speed for armature) per minute (rpm) A = No.

of parallel paths into which the „z“ no. of conductors are divided.

E = emf induced in any parallel path

E_g = emf generated in any parallel path

A = 2 for simplex – wave winding

A =P for simplex lap-winding

DC MOTOR

A dc motor is similar in construction to a dc generator. As a matter of fact a dc generator will run as a motor when its field & armature windings are connected to a source of direct current.

The basic construction is same whether it is generator or a motor.

Working principle:

The principle of operation of a dc motor can be stated as when a current carrying conductor is placed in a magnetic field; it experiences a mechanical force. In a practical dc motor, the field winding produces the required magnetic held while armature conductor play the role of current carrying conductor and hence the armature conductors experience a force. As conductors are placed in the slots which are on the periphery, the individual force experienced by the conductive acts as a twisting or turning force on the armature which is called a torque. The torque is the product of force and the radius at which this force acts, so overall armature experiences a torque and starts rotating. Consider a single conductor placed in a

magnetic field, the magnetic field is produced by a permanent magnet but in practical dc motor it is produced by the field winding when it carries a current. Now this conductor is excited by a separate supply so that it carries a current in a particular direction. Consider that it carries a current away from an current. Any current carrying conductor produces its own magnetic field around it, hence this conductor also produces its own flux, around. The direction of this flux can be determined by right hand thumb rule. For direction of current considered the direction of flux around a conductor is clock-wise. Now, there are two fluxes present

1. Flux produced by permanent magnet called main flux
2. Flux produced by the current carrying conductor

From the figure shown below, it is clear that on one side of the conductor, both the fluxes are in the same direction in this case, on the left of the conductor there gathering of the flux lines as two fluxes help each other. As against this, on the right of the conductor, the two fluxes are in opposite direction and hence try to cancel each other. Due to this, the density of the flux lines in this area gets weakened.

So on the left, there exists high flux density area while on the right of the conductor then exists low flux density area. The flux distribution around the conductor acts like a stretched ribbed band under tension. It exerts a mechanical force on the conductor which acts from high flux density area towards low flux density area, i.e. from left to right from the case considered as shown above.

In the practical dc motor, the permanent magnet is replaced by the field winding which produces the required flux winding which produces the required flux called main flux and all the armature conductors, would on the periphery of the armature gram, get subjected total the mechanical force.

Due to this, overall armature experiences a twisting force called torque and armature of the motor starts rotating.

Direction of rotation of motor

The magnitude of the force experienced by the conductor in a motor is given by $F = BIL$ newtons. The direction of the main field can be reversed by changing the direction of current passing through the field winding, which is possible by interchanging the polarities of supply which is given to the field winding. The direction of current through armature can be reversed by changing supply polarities of dc supplying current to the armature.

If directions of both the currents are changed then the direction of rotation of the motor remains undamaged. In a dc motor both the field and armature is connected to a source of direct current. The current through the armature winding establish its own magnetic flux the interaction both the main field and the armature current produces the torque, thereby causing the motor to rotate, once the motor starts rotating, already existing magnetic flux there will be an induced emf in the armature conductors due to generator action. This emf acts in a direction opposite to supplied voltage. Therefore it is called Back emf.

Significance of Back emf

In the generating action, when a conductor cuts the lines of flux, emf gets induced in the conductor in a motor, after a motoring action, armature starts rotating and armature conductors cut the main flux. After a motoring action, there exists a generating action there is induced emf in the rotating armature conductors according to Faraday's law of electromagnetic induction. This induced emf in the armature always acts in the opposite direction of the supply voltage. This is according to the lenz's law which states that the direction of the induced emf is always so as to oppose the cause producing it. In a dc motor, electrical input i.e., the supply voltage is the cause and hence this induced emf opposes the supply voltage. The emf tries to set up a current throughout the armature which is in the opposite direction to that which supply voltage is forcing through the conductor so, as this emf always opposes the supply voltage, it is called back emf and denoted as E_b . Through it is denoted as E_b , basically it gets generated by the generating action which we have seen

$$E = \frac{\phi ZNP}{60 A}$$

Voltage equation of a Motor

The voltage v applied across the motor armature has to (1) overcome the back emf E_b and

3. supply the armature ohmic drop $I_a R_a$

$$v = E_b + I_a R_a$$

This is known as voltage equation of a motor

Torque: The turning or twisting movement of a body is called Torque

$$T_{sh} = \frac{\text{output}}{(2\pi N)/60}$$

$$T_{sh} = 9.55(\text{output})/N$$

INTRODUCTION TO POLY PHASE INDUCTION MOTORS

Three-phase induction motors are the most common and frequently encountered machines in industry.

- simple design, rugged, low-price, easy maintenance
- wide range of power ratings: fractional horsepower to 10 MW
- run essentially as constant speed from no-load to full load
- Its speed depends on the frequency of the power source
 - not easy to have variable speed control
 - requires a variable-frequency power-electronic drive for optimal speed control.

CONSTRUCTION DETAILS OF INDUCTION MOTOR

An induction motor has two main parts

- a stationary stator
 - consisting of a steel frame that supports a hollow, cylindrical core
 - core, constructed from stacked laminations (why?), having a number of evenly spaced slots, providing the space for the stator winding .

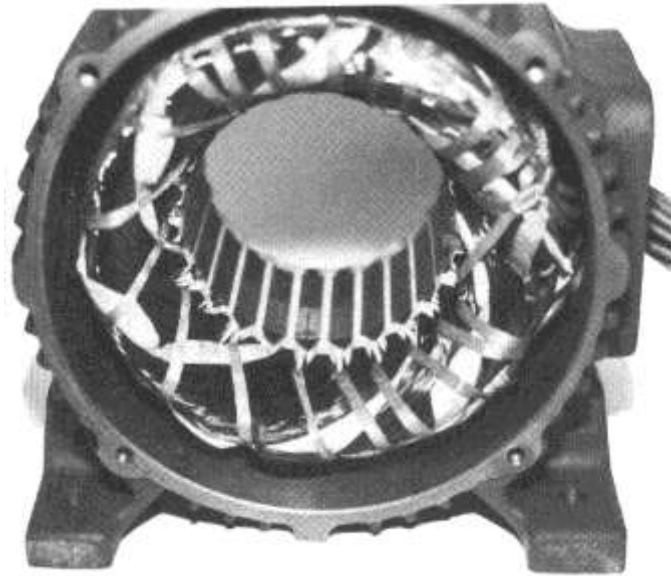

Fig: STATOR OF INDUCTION MOTOR

a revolving rotor

- composed of punched laminations, stacked to create a series of rotor slots, providing space for the rotor winding
- one of two types of rotor windings
- conventional 3-phase windings made of insulated wire (wound-rotor) » similar to the winding on the stator
- Aluminum bus bars shorted together at the ends by two aluminum rings, forming a squirrel-cage shaped circuit (squirrel-cage).

CONSTRUCTION OF CAGE AND WOUND ROTOR MACHINES

Two basic design types depending on the rotor design

Squirrel-cage: conducting bars laid into slots and shorted at both ends by shorting rings.

Wound-rotor: complete set of three-phase windings exactly as the stator. Usually Y-connected, the ends of the three rotor wires are connected to 3 slip rings on the rotor shaft. In this way, the rotor circuit is accessible.

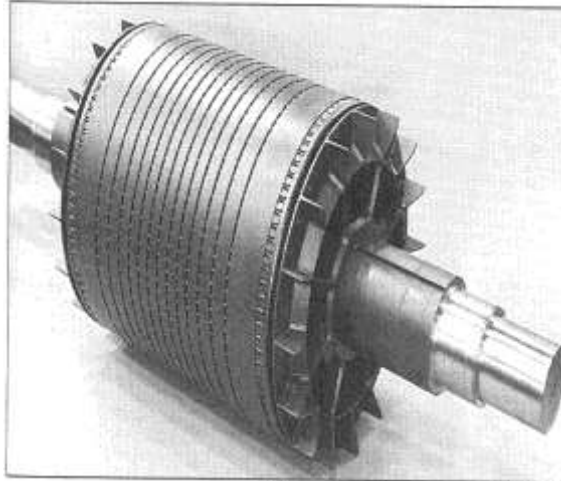

Fig:- Squirrel cage rotor

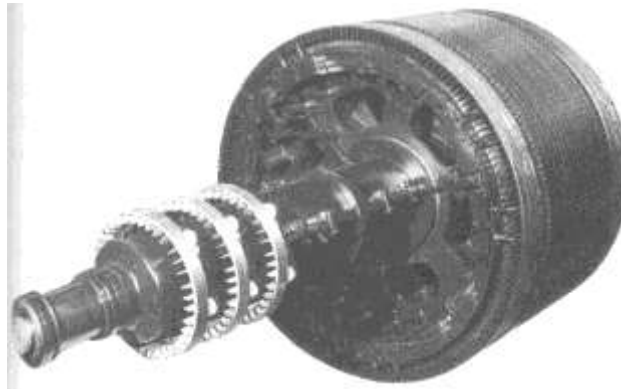

Fig: Wound rotor

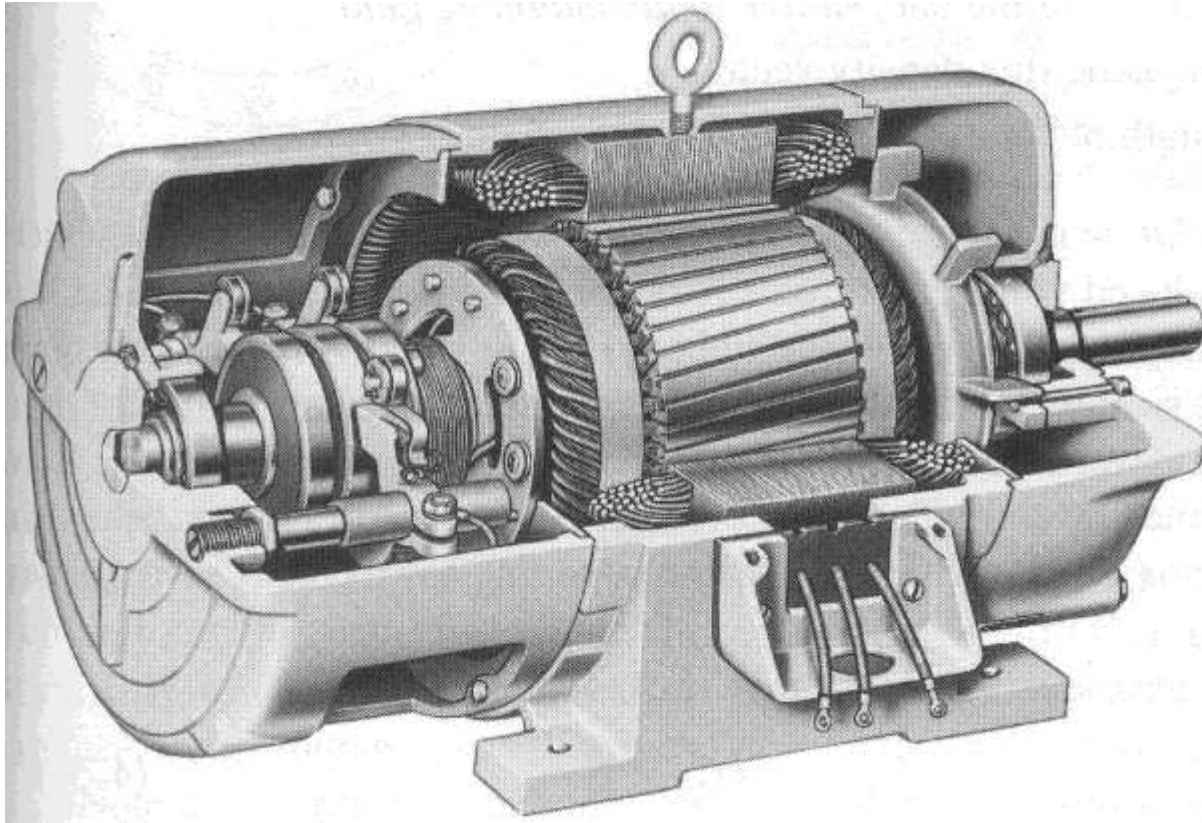

Fig:- Cutaway in a typical wound-rotor IM.

PRODUCTION OF ROTATING MAGNETIC FIELD

- Balanced three phase windings, i.e. mechanically displaced 120 degrees from each other, fed by balanced three phase source
- A rotating magnetic field with constant magnitude is produced, rotating with a speed

$$N_s = 120f_e/p$$

Where f_e is the supply frequency and

$$i_R = I_m \cos \omega t$$

$$i_Y = I_m \cos (\omega t - 120^\circ)$$

$$i_B = I_m \cos (\omega t + 120^\circ) = I_m \cos (\omega t - 240^\circ)$$

Please note that the phase sequence is R-Y-B. I_m is the maximum value of the phase currents, and, as the phase currents are balanced, the rms values are equal ($I_R = I_Y = I_B$)

Three pulsating mmf waves are now set up in the air-gap, which have a time phase difference of 120° from each other. These mmfs are oriented in space along the magnetic axes of the phases, R, Y & B, as illustrated by the concentrated coils in Fig. 29.2. Please note that 2-pole stator is shown, with the angle between the adjacent phases, R & Y as 120°, in both mechanical and electrical terms. Since the magnetic axes are located 120° apart in space from each other, the three mmf's are expressed mathematically as

$$F_R = F_m \cos \omega t \cos \theta$$

$$F_Y = F_m \cos (\omega t - 120^\circ) \cos (\theta - 120^\circ) \quad F_B = F_m \cos$$

$$(\omega t + 120^\circ) \cos (\theta + 120^\circ)$$

Wherein it has been considered that the three mmf waves differ progressively in time phase by 120° , i.e. $2\pi / 3$ rad (elect.), and are separated in space phase by 120° , i.e. $2\pi / 3$ rad (elect.). The resultant mmf wave, which is the sum of three pulsating mmf waves, is

$$F = F_R + F_Y + F_B$$

Substituting the values,
 (θ, t)

4. $F_m [\cos \omega t \cos \theta + \cos (\omega t - 120^\circ) \cos (\theta - 120^\circ) + \cos (\omega t + 120^\circ) \cos (\theta + 120^\circ)]$ The first term of this expression is

$$\cos \omega t \cos \theta = 0.5 [\cos (\theta - \omega t) + \cos (\theta + \omega t)]$$

The second term is

$$\cos (\omega t - 120^\circ) \cos (\theta - 120^\circ) = 0.5 [\cos (\theta - \omega t) + \cos (\theta + \omega t - 240^\circ)]$$

Similarly, the third term can be rewritten in the form shown. The expression is

$$F(\theta, t) = 1.5 F_m \cos (\theta - \omega t) + 0.5 F_m [\cos (\theta + \omega t) + \cos (\theta + \omega t - 240^\circ) + \cos (\theta + \omega t + 240^\circ)]$$

Note that $\cos (\theta + \omega t - 240^\circ) = \cos (\theta + \omega t + 120^\circ)$, and $\cos (\theta + \omega t + 240^\circ) = \cos (\theta + \omega t - 120^\circ)$.

If these two terms are added, then

$$\cos (\theta + \omega t + 120^\circ) + \cos (\theta + \omega t - 120^\circ) = -\cos (\theta + \omega t)$$

So, in the earlier expression, the second part of RHS within the capital bracket is zero. In other words, this part represents three unit phasors with a progressive phase difference of 120° , and therefore add up to zero. Hence, the resultant mmf is

$$F(\theta, t) = 1.5 F_m \cos (\theta - \omega t)$$

The peak value of the resultant mmf is $F_{peak} = 1.5 F_m$.

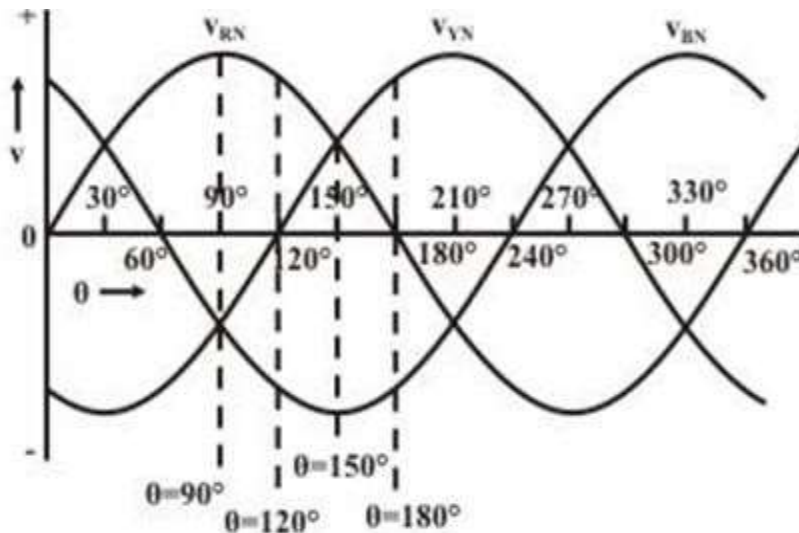

Three-phase voltage waveforms with phase sequence R-Y-B.

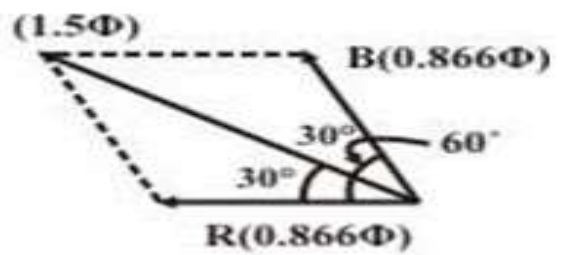
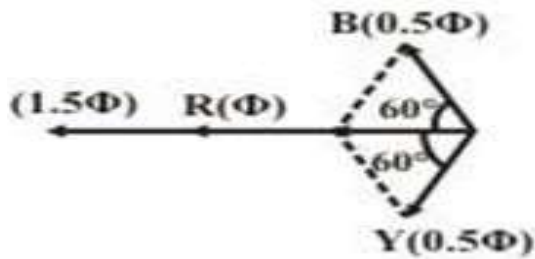
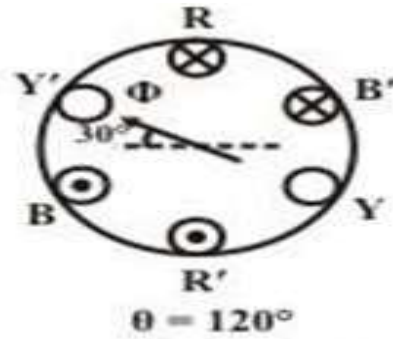
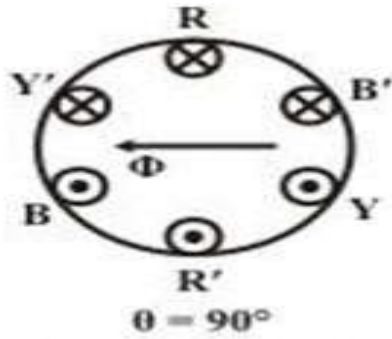

P is the no. of poles and n_{sync} is called the synchronous speed in *rpm* (revolutions per minute).

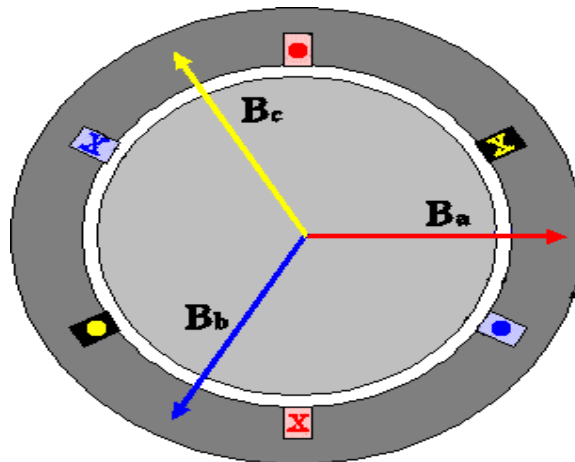

PRINCIPLE OF OPERATION

- This rotating magnetic field cuts the rotor windings and produces an induced voltage in the rotor windings.
- Due to the fact that the rotor windings are short circuited, for both squirrel cage and wound-rotor, and induced current flows in the rotor windings
- The rotor current produces another magnetic field
- A torque is produced as a result of the interaction of those two magnetic fields

Where τ_{ind} is the induced torque and B_R and B_S are the magnetic flux densities of the rotor and the stator respectively.

SLIP

$$S = \frac{N_S - N_R}{N_S}$$

Where s is the slip

Notice that: if the rotor runs at synchronous speed

$$s = 0$$

If the rotor is stationary

$$s = 1$$

Slip may be expressed as a percentage by multiplying the above eq. by 100, notice that the slip is a ratio and doesn't have units

ROTOR FREQUENCY

Frequency of the rotor's induced voltage at any speed n_m is

$$F_R = sF_S$$

- When the rotor is blocked ($s=1$), the frequency of the induced voltage is equal to the supply frequency.
- On the other hand, if the rotor runs at synchronous speed ($s = 0$), the frequency will be zero.

TORQUE EQUATION

- While the input to the induction motor is electrical power, its output is mechanical power and for that we should know some terms and quantities related to mechanical power
- Any mechanical load applied to the motor shaft will introduce a Torque on the motor shaft. This torque is related to the motor output power and the rotor speed.

$$\text{Thus } T = \frac{3 \times V_1^2 \times R_2'}{s \times \omega_s \times [(R_{new} + R_2'/s)^2 + (X_{th} + X_2')^2]}$$

From this equation we get $R_{new} = \frac{\sqrt{3 \times V_1^2 \times R_2'} - R_2'}{\sqrt{s \times \omega_s \times T}}$

TORQUE-SLIP CHARACTERISTICS

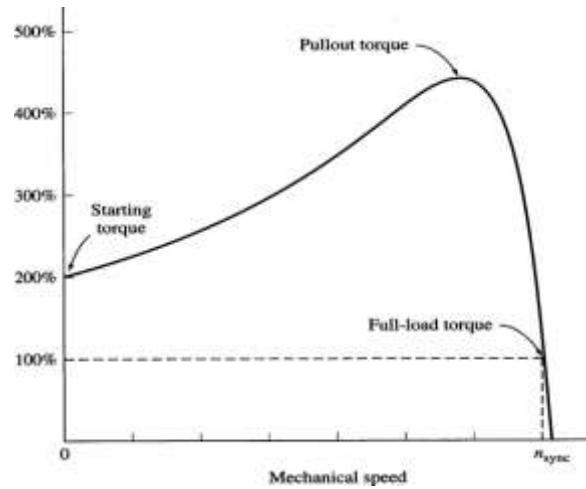

1. The induced torque is zero at synchronous speed. Discussed earlier.
2. The curve is nearly linear between no-load and full load. In this range, the rotor resistance is much greater than the reactance, so the rotor current, torque increase linearly with the slip.
3. There is a maximum possible torque that can't be exceeded. This torque is called *pullout torque* and is 2 to 3 times the rated full-load torque.
4. The starting torque of the motor is slightly higher than its full-load torque, so the motor will start carrying any load it can supply at full load.
5. The torque of the motor for a given slip varies as the square of the applied voltage.

If the rotor is driven faster than synchronous speed it will run as a generator, converting mechanical power to electric power.



UNIT V

Basic Instruments

Principle of instruments:

All electrical measuring instruments depend for their action on one of the many physical effects of an electric current or potential and are generally classified according to which of these effects is utilized in their operation. The effects generally utilized are:

1. Magnetic effect-for ammeters and voltmeters usually.
2. Electro dynamic effect-for ammeters and voltmeters usually.
3. Electromagnetic effect-for ammeters, voltmeters ,wattmeters and watt hour meters.
4. Thermal effect-for ammeters and voltmeters.
5. Chemical effect-for d.c.ampere-hour meters.
6. Electro static effect-for voltmeter sonly

Permanent Magnet Moving Coil (PMMC): A moving coil instrument consists basically of a permanent magnet to provide a magnetic field and a small lightweight coil is wound on a rectangular soft iron core that is free to rotate around its vertical axis. When a current is passed through the coil windings, a torque is developed on the coil by the interaction of the magnetic field and the field set up by the current in the coil. The aluminum pointer attached to rotating coil and the pointer moves around the calibrated scale indicates the deflection of the coil

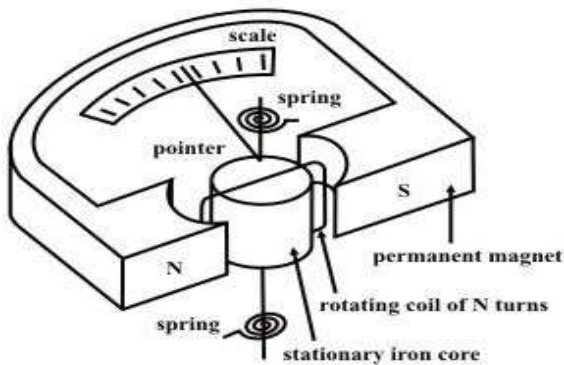

Permanent Magnet Moving Coil Instrument.

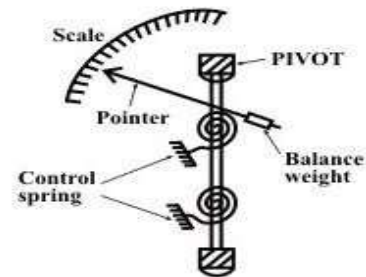

Principle of operation: the interaction between the induced field and the field produced by the permanent magnet causes a deflecting torque, which results in rotation of the coil.

Deflecting Torque:

If the coil is carrying a current of i , the force on a coil side = $i \text{ amp } B l N$ (newton, N).

\therefore Torque due to both coil sides = $2r B i l N m = G i N m$

Controlling Torque: The value of control torque depends on the mechanical design of the control device.

For spiral springs and strip suspensions, the controlling torque is directly proportional to the angle of deflection of the coil.,ie Control torque = $C\theta$

Damping Torque:

It is provided by the induced currents in a metal former or core on which the coil is wound or in the circuit of the coil itself. As the coil moves in the field of the permanent magnet, eddy currents are set up in the metal former or core. The magnetic field produced by the eddy currents opposes the motion of the coil. The pointer will therefore swing more slowly to its proper position and come to rest quickly with very little oscillation. Electromagnetic damping is caused by the induced effects in the moving coil as it rotates in magnetic field, provided the coil forms part of closed electric circuit.

Moving Iron Instruments:

The deflecting torque in any moving-iron instrument is due to forces on a small piece of magnetically „soft“ iron that is magnetized by a coil carrying the operating current. In repulsion type moving-iron instrument consists of two cylindrical soft iron vanes mounted within a fixed current-carrying coil. One iron vane is held fixed to the coil frame and other is free to rotate, carrying with it the pointer shaft. Two irons lie in the magnetic field produced by the coil that consists of only few turns if the instrument is an ammeter or of many turns if the instrument is a voltmeter. Current in the coil induces both vanes to become magnetized and repulsion between the similarly magnetized vanes produces a proportional rotation. The deflecting torque is proportional to the square of the current in the coil, making the instrument reading is a true „RMS“ quantity Rotation is opposed by a hairspring that produces the restoring torque. Only the fixed coil carries load current, and it is constructed so as to withstand high transient current. Moving iron instruments having scales that are nonlinear and some what crowded in the lower range of calibration.

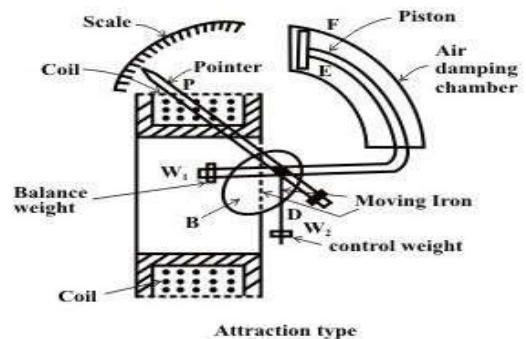
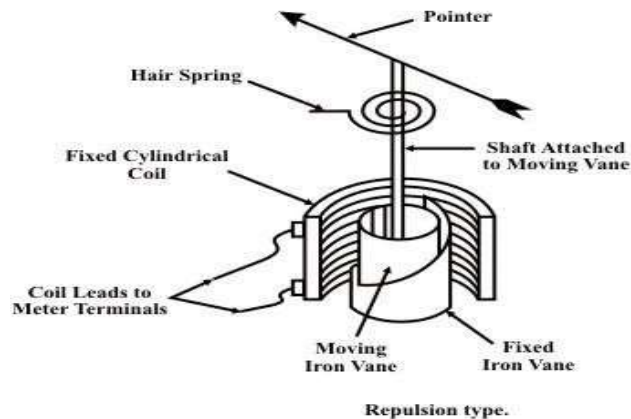



Attraction type instrument consists of a few soft iron discs (B) that are fixed to the spindle (D), pivoted in jeweled bearings. The spindle (D) also carries a pointer (P), a balance weight (W_1), a controlling weight (W_2) and a damping piston which moves in a curved fixed cylinder (F). The special shape of the moving-iron discs is for obtaining a scale of suitable form.